

Name:

Tutor Group: 11



**Working together to
turn your child's
potential into reality.**



**Year 11
AUTUMN
Knowledge
Organisers**

Homework Principles 2023-2024

Our Homework Principles are based on current, influential research:

At John Willmott School we set homework which supports students' understanding of their carefully sequenced curriculum as well as developing their committed and self-disciplined approach to their own academic studies. We know that homework has an impact by enabling pupils to undertake independent learning to practice and consolidate skills, learn key vocabulary, prepare for lessons, or revise for exams.

The Education Endowment Fund suggests that setting homework at Secondary School can accelerate learning by up to 5 months, however it is the quality of tasks set rather than quantity which enhances progress, which is why we are clear in our principles when planning homework against our curriculum implementation.

ACCESSIBLE

- A new Knowledge Organiser will be issued to all students at the start of each term. This will form the basis for most homework so that students have the resources at hand
- Homework tasks should be short and focused ensuring accessibility for all students
- Students will be set homework weekly for most subjects with adequate time for completion
- Students will be taught independent learning strategies as well as explicit teaching of our virtues and school routines to build learning habits

ACCESSIBLE

PRECISE

- Tasks have a defined and exact outcome
- Students will be directed to practise or retrieval or embedding the curriculum
- The way this will be assessed is communicated to students, as well as when this will happen
- Homework is designed to link to classroom learning, with clear signposting to prior, current or future knowledge
- Teachers are asked to plan homework tasks for the term in line with long term plans and summative assessments- this will be shared with students and parents

PRECISE

INFORMATIVE

- Teachers use homework as part of their formative assessment to adapt teaching to better respond to student need in terms of what students know and what they don't know yet
- Teachers will gather data through a variety of quality first teaching routine techniques which may include: Do Now Activities, Exit Tickets, Deliberate Practice; Questioning, Mini Whiteboards
- Student engagement is monitored as well as progress and attainment

INFORMATIVE

JWS

Year 11

Knowledge Organisers

Contents

Year 11 Subjects

Art and Design

Business BTEC

Business Studies

Drama

English

French

Geography

History

Hospitality and Catering

Information Technology

Media Studies

Photography

Physical Education

Physical Education GCSE

Religious Education

Science

Spanish

Technology Product Design

Art & Design: Fine Art

Urban Portraiture

1. AO1: Developing Ideas: 24 Marks

Artist Inspiration

- Kris Trappeniers
- Cath Riley
- Francoise Nielly
- Kehinde Wiley
- David Newman White
- Nick Gentry
- Mark Powell
- Richard Day
- Joshua Miels
- Chrissy Angliker
- Stephen Conroy
- Peter Monkman
- Ant Carver
- Tristan Eaton
- Laolu Senbanjo – (style inspiration)

Research must include:

Primary Sources: recording from life or your own photographs.
Secondary Sources: recording from work created by other people.
Photographs: Take a set of photographs to record from.



2. A02: Experimenting: 24 Marks

Tone: Use varying grades of tone from dark to light to create a realistic drawing

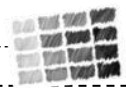

Contour Lines: Experiment with drawing a portrait using only line to depict the form and features.

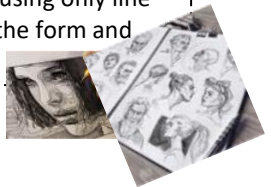

Colour: Experiment with colour mixing to make a larger colour spectrum. Mix, layer and blend complementary colours to make a colour darker instead of using black. E.g. Red + Green.

Colour: Experiment with colour mixing to make a larger colour spectrum. Mix, layer and blend complementary colours to make a colour darker instead of using black. E.g. Red + Green.

3. WOW WORDS

- Layer
- Tear
- Collage
- Spray
- Stain
- Splatter
- Cut
- Combine
- Fragment
- Stencil
- Stamp
- Drip
- Pierce Holes
- Stitch
- Connect



4. A03: Recording: 24 marks

Record your chosen portrait and ideas in a well thought out creative way.

Annotate your work to describe what you are doing, how and why.

Ensure you are made clear links to your artist and that your portrait designs show your ability to record in a skilful manner.

5. A04: Realising intentions

Use a combination of photographs, drawings, paintings and text/words to illustrate the **urban portraiture** theme using a range of materials, techniques and processes.

Is your work presented aesthetically and coherently?
 Is your imagery of high-quality
 Do your ideas clearly link showing a journey;
 Consider you use of typography (lettering style)does it match, suit, complement the theme?

6. Sketchbook presentation

Questions to consider

Does your sketchbook flow from beginning to the end?
 Is your work thoughtfully presented?
 Does your work make connections to your selected artists?
 Have you revisited and refined your work to ensure that the visual quality is the best that you can achieve?
 Are your own ideas clearly presented and articulated in your annotations?



KNOW IT

Explore by gathering information for research and inspiration. Research using books, the internet, magazines and remember to record where the information is taken from. Look at artists that have based their work on similar themes.

Selects a range of artist to inspire you. Use box 1 on this knowledge organiser to guide you or research your own by exploring artists on the internet, in books or magazines.

Identify the key features of an artists work. Identify the characteristics of the artists style/techniques. Find out key facts about the artist. Create a visual study if the artists work.

Create design ideas that show clear inspiration to the artists work as well as incorporating your own ideas.

Realise your intentions in a final outcome that shows refinement and development from your design ideas.

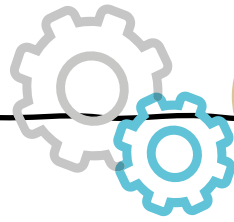

THINK IT

Research and analyse the work an artist. How can an artist inspire you? How can you link your work to your chosen artist?

Recording of ideas – have you selected appropriate source material? (images, photographs etc) How will you present this in your visual mind map as an introduction for your project?

How have you recorded your ideas?

Have you developed your observational awareness skills? Have you developed your drawing skills?

Have you made links to your selected artist? How does this show in your design ideas?

Have you refined your work? How have your made visual improvements?

Is your work throughout your sketchbook consistent with the visual quality and the connections to your ideas?

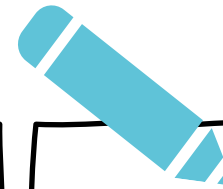

GRASP IT

Select and research a range of artists such as those in box 1 on this knowledge organiser or find your own. Search the theme of the artist's work e.g Urban portraiture art. You could then be more specific and search words such as black and white, drawing, illustrative, painting depending upon the style of work you enjoy and the media that you prefer to work in. What can you see? Is it a specific place/or person? (Consider time of day/weather/season/place/setting etc.)•What do you think it represents?•Does it tell a story? Can you imagine what happened before or what might happen next?•Could the work have symbolic or moral meaning?•How does it link with social, cultural or political history of that time?•How is it arranged? Is there a focal point?•What mood/atmosphere does it create? How does it make you feel?

Explore and experiment with a range of media, techniques and processes and make links to your artists that have inspired you.

Annotate throughout your sketchbook to discuss your ideas and to show what works and what doesn't. Explain your thought processes.

Business BTEC

Unit 3 Promotion and Finance for Enterprise

1. Payment Methods

Method	
Cash	Cash is notes and coins used in a wide range of values
Credit Card	It is issued by financial institutions such as banks, allowing consumers to delay payment for goods and services
Debit Card	Is issued by banks for payments for goods and services which will be directly deducted from your account
Direct Debit	Agreement made with the bank to allow a third party to take out money from your account on a set day to pay for the goods and services that you receive
Payment system	A payment system is any system used to settle financial transactions through the transfer of monetary value. This includes the institutions, instruments, people, rules, procedures, standards, and technologies that make its exchange possible.

3. Promotional Mix

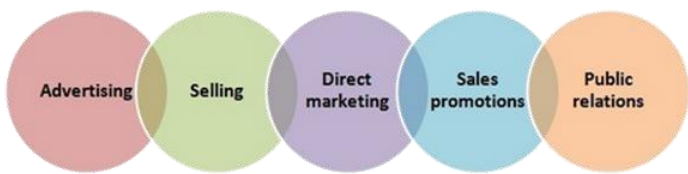

2. Market Segmentation



4. Business Planning

Business plan	Is a document setting out what a business does and what it hopes to achieve in the future. Can be used by start-up businesses or growing businesses completing and expansion or opening a new location.
Uncertainty	Occurs where there is a lack of information about a situation. This means the outcome or consequences are very difficult to predict.
Risk	Is the possibility of something going wrong.
Revenue	Is the income that a firm receives from selling its goods or services. It is also referred to as "turnover". It is measured by the number of units sold multiplied by the selling price.
Total costs	Are fixed costs plus variable costs.
Fixed costs	Are those costs that do not change when a business changes its output.
Variable costs	Are the costs that vary directly with the businesses level of output.



KNOW IT

- What are the elements of the promotional mix?
- What is the purpose of each element?
- What are the different types of market Segmentation?
- What factors influencing the choice of promotional methods.
- What are the different payment methods?
- What are the Key business terms in relation to business planning.

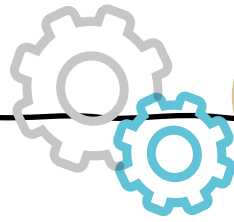

THINK IT

- Who is the target market for the following and explain :
- Small Toyota Aygo with a 1 litre engine?
- Why is the market segmented?
- Can you identify the 5 elements that make up the promotional mix?

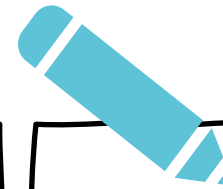

GRASP IT

- Explain why credit card may be the preferred payment method for people booking holidays.
- Explain the difference between cash and profit.
- Compare 2 areas of the promotional mix, look at their similarities and differences.

Business Studies GCSE

Unequal World Development

1. Cash Flow

Cashflow is the term used to describe money entering and exiting a business. If cashflow is positive, then the business has the funds available to operate. If it is negative, they may not be able to pay their debts or be able to afford it

Cash is king, and having enough cash available (either from sales or from borrowing) is vital. If a business has negative cashflow

4. Cash Flow Solutions

- Re-scheduling payments
- Overdrafts \Rightarrow reducing cash outflow
- Increasing cash inflow
- finding new sources of finance.

2. Sources of Finance

Method	Benefits / Issues
Friends / Family	May not charge interest, or may let you repay over a more relaxed time-frame – but could harm relationships
Retained Profit	No interest and money is available instantly – but once it has been spent it is gone. Borrowing may be needed later.
Sale of Assets	Selling unwanted goods may result in the business getting back less than they paid.
Loan / Mortgage	Interest is charged on the loan – there is a rigid schedule for repayment. Reliable, interest rates are low.
Credit Card / Overdraft	Pre-arranged borrowing from a bank – can be spent like money – instant access – but typically high interest rates.
Sale and Leaseback	For items the business still needs, they can sell the building (e.g.) and then lease or rent it back from the new owner.
Trade Credit	Buy now-pay later. Enables business to obtain the resources they need, then are given x days to repay.
Hire Purchase	A deposit is paid, the business receives the goods and then is lent the remainder which they repay over time with interest.

5. Consequences of uneven development

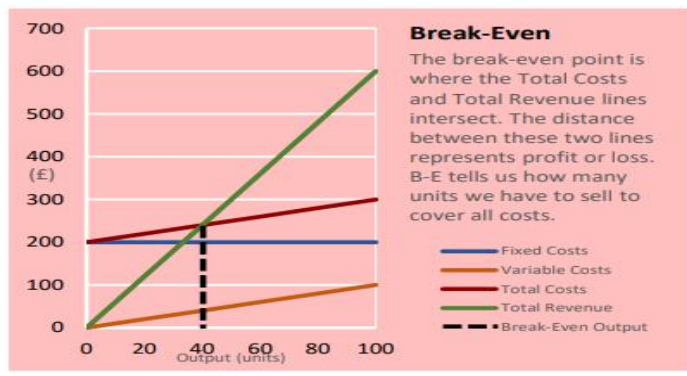

3. Cash Flow Forecast

Cashflow Forecast Businesses need to predict whether they are likely to have any cashflow problems in the near future, as they may need to put finance in place to cover any deficit between income and expenditure.



6. Break even

Profit = income is greater than expenditure
 Loss = expenditure is greater than income
 To calculate a businesses profit/loss we have to understand the relationship between costs and revenue.
 Total Costs : $FC + VC = TC$
 TR=Total revenue is calculating the selling price of the product multiplied by the number of products



KNOW IT

- Define cash flow
- State issues that effect cash flow within a Business
- State a range of different sources of finance
- Understand the meaning of the word forecast and understand how this is linked to cash flow projections
- Define cash flow solutions
- Define what break even is and how its used
- How to use different financial calculations

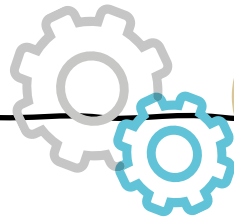

THINK IT

- Explain why cash flow is important and explain the differences between positive and negative
- Explain the main factors that effect Business cash flow
- Explain the advantages and disadvantages of different sources of finance.
- Demonstrate the main advantages of cash flow forecasting
- Explain how different cash flow solutions work in different situations
- Analyse a break even graph and show the break even point and margin safety
- Use financial calculations to answer financial questions

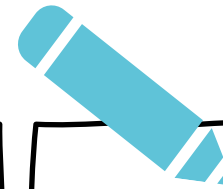

GRASP IT

- Analyse a cash flow statement and advise a Business of the best form of action
- Analyse the different uses of different sources of finance for different situations
- Apply cash flow forecasting to a set Business situation
- Create a break even chart to include all costs and show the margin of safety and the break even point

Year 11

Business Studies GCSE

Unequal World Development

Drama: Scripted Performance

Scripted Performance

Your Scripted performance unit is split into 3 different parts. It is worth 30% of your GCSE and will be completed this yeawsqsr.

You have been given a monologue and a group piece, you will need to start learning the lines for these as soon as you can to help your rehearsal. Your monologue will be 1-3 minutes and your group piece's length (2-8 mins) will depend on your group size.

Alongside these performances, there is a short piece of coursework with 4 questions.

Key words

Mime	Vision
Gesture	Intention
Facial Expression	Style
Posture	Naturalistic
Movement	Non-Naturalistic
Stance	Rehearsal
Costume	Development
Props	Set
Exaggeration	Staging
Clear	Proxemics
Mirroring	Symbolism
Sculpting	Semiotics
"Yes, and..."	
"What if?"	

Concept Proforma - Coursework

The accompanying coursework is always the four same questions, they are below. You should recognise them from our lessons.

1. What are the major demands of the text? You should consider the structure of the extracts in the context of the whole performance text and the original intentions of the playwright.

2. What is your artistic vision for the two extracts?

3. How did you develop your role(s) or design(s)? As an actor you should consider semiotics, the use of language, gesture and expression. As a designer you should consider proxemics, mood, supporting characters and supporting the chosen genre and style.

4. How do you want the audience to respond to your presentation of the extracts as an actor or designer? Give specific examples from each extract.

Why learn my lines?

You need to learn your lines to make it possible to develop your characterisation. If you don't learn them soon, you can't look like the character, as you'll always have the script in the way.

Coursework explained

1) This wants to make sure you understand what your character is doing, why they are doing it and how the playwright wanted them to be seen

2) This wants you to demonstrate a clear plan for how the scenes will look and what role your character will play in those scenes

3) This section wants you to discuss the rehearsal process, it wants you to show that you have thought carefully about how you have acted and the impact of those choices on your audiences.

4) This section asks you to carefully consider the impact that your acting has on the audience.



KNOW IT

1. Do I know what I have to do in my Scripted performance Unit?
2. Do I know when I will be assessed?
3. Do I know how I am marked for my devising unit?
4. Do I know how many words roughly each coursework question should be?
5. Do I know how to develop my performance through rehearsal techniques?

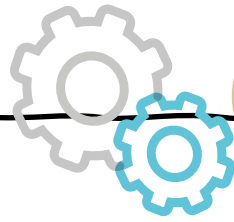

THINK IT

1. In your scripted unit you will be assessed performing a Monologue (DNA) a group Piece (DNA) and with a piece of coursework
2. You will be assessed by a visiting examiner who will be invited to a performance alongside an audience
3. You are marked practically on your communication (20) and your Performing skills (20)
4. About 500 words each section, which covers your monologue and your group piece.
5. There are many useful rehearsal techniques, but STILL IMAGE, THOUGHT TRACK, SCULPTING, ROLE SWAP, FLASHBACK and IMPROV could all be useful ways to start

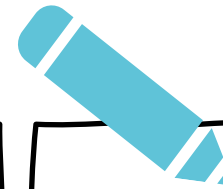

GRASP IT

Challenge

Think of what you can produce to help your group clearly understand your vision. There isn't a limit here, but you can use anything that you produce to help evidence your research and development. Below is a list of tasks you may choose to try:

- Diary entry for a character
- Relationship map
- Emotions graph
- Storyboard
- Mind Map
- Write a new scene
- Sketch a stage plan
- Design a costume
- Design the set
- Create a mood board
- Write a Role on the Wall
- Create a Character Profile
- Write a monologue
- Create a timeline
- Look for facts and stats
- Try to find practitioners
- How to Mark a moment?
- Research performance Styles
- Create a Flashback
- Create a Flashforward
- Use "Magic If"
- Use Given Circumstances
- Record your monologue
- Film your monologue
- Role swap with someone else

Question 2

Question Two: How does the writer use language to...? 8 marks

Language devices	Effects
Adjective	Describes the noun.
Alliteration	Makes the phrase <u>memorable</u> . Adds <u>rhythm and rhyme</u> .
Adverb	Describes an action.
Metaphor	Compares two different things.
Onomatopoeia	Sounds like.
Personification	Brings objects to life
Simile	Compares two different things.

English: Language Paper One

What - The writer purposely creates a sense of foreboding through use of a semantic field of fear.

How - The noun 'shadows' unsettles the reader due to the unknown element that is implied. When used in conjunction with the verb 'grew' it suggests that this situation is getting worse.

Why - The growing 'shadows' build a sense of continuous uncertainty and mystery as we do not know who the shadowy figures are and what kind of danger they pose, forcing sympathy with the boy - we are invested in his safety. The boy's fear symbolises a wider fear of the unknown and loss of innocence.

Question 4

Year 10

Question Four: How far do you agree that...? 20 marks

Here are two examples of how you can write your response.

- **Respond** to the statement and make a comment on it
- **Support** with quotes
- **Identify methods (language and structural techniques)**
- **Evaluate** methods in relation to the statement.
- **Comment** on the ideas in the statement, the meaning of the quote and its effect

Question 3

Question Three: How does the writer use structure to...? 8 marks

What - The writer changes the focus from the bus to the girl with red hair
How - 'eyes the colour of that green ribbon shot with gold they had got from Paris last week'
Why - to create a sense of contrast and envy, suggesting to us the sadness Rosabel feels with her life. The girl represented what Rosabel wishes she had. Focusing on this woman makes us empathise with her situation. We see how she lives and then how others more fortunate live. The drab, unpleasant bus represents her life, and the girl is the one attractive and pleasant part of her day.

Structural devices	Definitions
Narrative perspective	1 st person - 'I' makes the text more relatable/believable. 3 rd person - 'he/she/they' gives the reader more information about multiple perspectives in the text.
Exposition	Initial ideas: setting, character, plot detail.
Climax	Most intense or decisive point.
Motif	Reoccurring ideas/objects/elements
Linear/non-linear narrative	Events told chronologically. Events not told chronologically
Cyclical narrative	Ends the way it begins.

Question 5

Write a description or a narrative (40 marks).

- DROP**
The reader into the action
- SHIFT**
To another time (e.g. flashback) or contrasting mood or alternative place.
- ZOOM IN**
On a tiny detail back where you started.
- ZOOM OUT**
And leave the location.

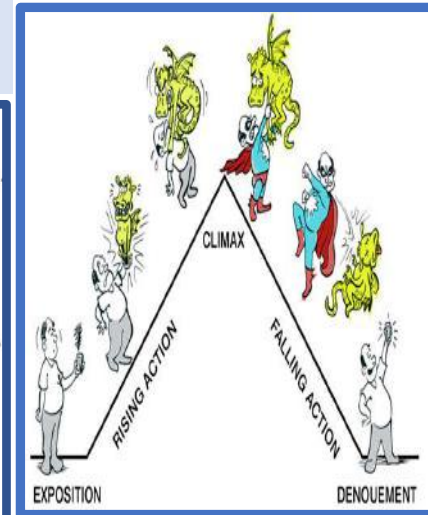

- I -ing word
- S simile
- P preposition
- A adverb / adverbial
- C connective
- E -ed word



KNOW IT

1. What is implicit and explicit information?
2. What do the letters in AAAMOPS stand for? What is the effect of each letter?
3. Identify the six structural features and write down their definitions.
4. What does evaluate mean?
5. Identify discourse markers that demonstrate addition and contrast?
6. What do the letters in ISPACE stand for?
7. What is the difference between a flat character and a round character?
8. What does Drop, Shift, Zoom In, Zoom Out mean?

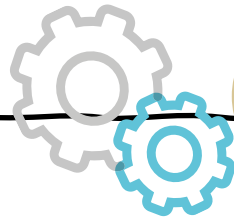

THINK IT

1. What do you need to do for question one?
2. What do you do with the extract for question 2? Which paragraph structure do you use?
3. What do you do with the extract for question 3? Which paragraph structure do you use?
4. What do you do with the extract for question 4? Which paragraph structure do you use?
5. What could you be asked to write for question 5?
6. What do you need to include when answering question 5?

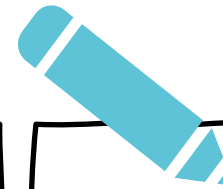

GRASP IT

1. Read a newspaper article or fictional text and practice finding four things about the given topic.
2. Identify and annotate a newspaper article or fictional text for language devices. Choose 3 techniques and comment on their effects.
3. Watch a film and identify the structural techniques used in the beginning, middle and end. Try to focus on why the film has been casted this way. You could create a storyboard.
4. Read two opposing views about controversial topics such as: the death penalty, animal rights, GMO, etc. Evaluate how the writers present their points. Decide which article is most effective and explain why.
5. Use thought provoking images as stimuli for a narrative or description. Write a four/five paragraph plan using the: Drop, Shift, Zoom in and Zoom Out technique. Choose one plan to write in paragraphs. Remember to include all of the elements listed in your success criteria (Think it – question 6).



English: Language Paper 2

Year
10

Question Two: Compare (summary) 8 marks

EXAMPLE

Statement - Muhlhausen advocates the death penalty, arguing

Quotation - 'the death penalty ultimately leads to less crime'.

Inference - We can infer that he sees capital punishment as an effective deterrent even if many people have to die before others abide by the law.

Statement - **However**, Dickens is strongly against it. He is clearly disgusted by the use of public hangings,

Quotation - describing them as a 'spectacle'.

Inference - This word has clear connotations of entertainment, immediately drawing our attention to the inappropriateness and sinfulness of treating death in this way.

COMPARATIVE CONNECTIVES

Whereas
Although
Even though
Similarly
On the other hand
Despite
However
In the same way
Equally
Otherwise
Alternatively
Nevertheless

Question Three: How does the writer use language to...? 12 marks

EXAMPLE

What: - The writer uses the animalistic verb
How: - 'flocked' to describe the way the spectators gather and huddle together to watch, suggesting a pack mentality or herd behaviour.

Why: *We understand that Dickens clearly condemns this collective, emotionally unruly behaviour and perceives it as subhuman.
*On a wider level, this is particularly persuasive from a 19th century perspective as they believed in rational, pious behaviour.

Language devices	Effects
Facts	To make the information more believable .
Repetition	To emphasise ..
Emotive language	To evoke the feeling of...
Triples	Emphasises the perspective of...
Direct Address	Directly engages the audience

Question Four: Compare attitudes (methods) 16 marks

Statement - Both Muhlhausen and Dickens use evocations of vivid scenes to shock the reader into sharing their view of the death penalty as the only possible viewpoint.

Point - Muhlhausen advocates the harshest punishment because he is disgusted by the crime; feelings which are obvious when describing Ringo's

Evidence - 'two first degree murders...so heinous and inherently wrong'.

Analysis - The adverb 'inherently', when applied in this way suggests that the crimes themselves are unnatural: a corruption of human nature and therefore the ultimate punishment is necessary.

Reader's Response - By appealing to the reader's empathy with the victims and emphasising the callousness of the crimes, Muhlhausen compels the reader to agree with the death penalty in these circumstances.

Signpost/Point - Equally, Dickens evokes the corruption of humanity provoked by the 'spectacle' of public hangings as he depicts

Evidence - 'the shrillness of the cries and howls'.

Analysis - The human 'cries' become animalistic 'howls'; these verbs applying to both criminals and onlookers as they convey the descent of civilised composure into instinctual reaction.

Reader's Response - We conclude that Dickens' use of dehumanising language portrays a scene where public hangings bring out the absolute worst in humanity as they display sadistic and sinful pleasure in watching this suffering and humiliation.

Advocates
Criticises
Challenges
Demonises/dehumanises
Ridicule/deride/mock

Rhetorical question
Interrogative
Imperative
Exclamatory
Juxtaposition

Question Five: Write a speech/article/letter/essay/text for a leaflet 40 marks

TAP the Text

Text Type - what are you being asked to write? (EG Letter or Article)

Audience - who are you writing for?

Purpose - what are you trying to achieve? (Explain, Persuade, Argue, Instruct/Advise)

Techniques

Alliteration & anecdotes
Facts
Opinions
Rhetorical questions
Emotive language/exaggeration
Statistics
Triplets (rule of three)
Repetition
You (direct address)

Article

- *Think about the TAP.
- *Headline and Strapline.
- *Introduction to create interest - (include who, what, where, when, how and why).
- *3-4 middle paragraphs.
- *Short but effective conclusion.
- *AFORESTRY techniques.

Letter

- *Think about the TAP.
- *Address and date in the top right of the page.
- *Address of the person you are writing to on the left.
- *Date.
- *Dear Mrs Smith = yours sincerely.
- *Dear Sir/Madam = yours faithfully.
- *Short introductory paragraph.
- *3-4 middle paragraphs.
- *Concluding paragraph summarising ideas.
- *AFORESTRY techniques.



KNOW IT

1. What is the definition of summarise?
2. What is an inference?
3. What does the letters in AFORESTRY stand for?
4. What the effect of four devices from AFORESTRY?
5. What is the difference between an attitude and a perspective?
6. Which connectives show similarities, and which show differences?
7. What does the writer's methods mean?
8. What do the letters in TAP mean?
9. What are the conventions of a letter?
10. What are the conventions of an article?
11. What are the conventions of a speech?

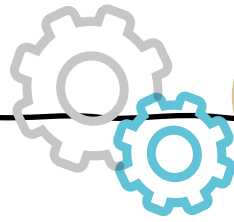

THINK IT

1. What do you need to do for question 1?
2. What do you do with the extracts for question 2? Which paragraph structure do you use?
3. What do you do with the extract for question 3? Which paragraph structure do you use?
4. What do you do with the extracts for question 4? Which paragraph structure do you use?
5. What could you be asked to write for question 5?
6. What types of figurative language should you create?
7. List the success criteria for AO5 and AO6.

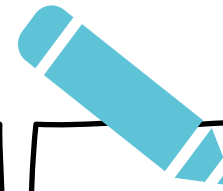

GRASP IT

1. Apply your knowledge and understanding of how to synthesise the information in non-fiction extracts to any of the papers on the AQA website.
2. Do you come across any primary sources in geography or history, can you TAP the article?
3. Look at a set of instructions (building furniture, cooking etc) how have they ensured that the instructions are logical? Think about discourse markers.
3. Read a non-fiction text on a topic that interests you, what is the impact of figurative language use within the text?
4. Read a non-fiction text on a topic of your choice. Consider why are the author's attitudes important for the reader to understand?



French: Global and Social Dimension

1. HELPING OUT

On peut	You can ...
faire du bénévolat	do charitable
parrainer un enfant	work
donner de l'argent à	adopt a child
une association	give money to a
caritative	charitable
recycler	organization
Il faut	recycle
agir	We must ...
lutter contre (la	act
pauvreté)	fight against
participer à des	(poverty)
manifestations	participate in
éduquer les gens	demonstrations
signer les pétitions	educate people
	sign petitions

2. ENVIRONMENTAL PROBLEMS

Le plus grand problème environnemental,	The biggest environmental
c'est	problem is ...
le changement climatique	climate change
le manque d'eau potable	lack of drinking water
la disparition des espèces	the extinction of species
la destruction des forêts tropicaux	the destruction of tropical forests
la surpopulation	overpopulation
la pollution (de l'air)	(air) pollution
la sécheresse	drought
les inondations	floods
les incendies	fires
les arbres nous donnent l'oxygène et	trees give us oxygen and we cut
nous les coupons tous les jours	them down everyday
On détruit la planète	We are destroying the planet
C'est très inquiétant/ catastrophique	It's very worrying/ catastrophic

3. STAR WORDS

à peu près	almost/about
aucun(e)	not any
autre	other
en tout	in all
la plupart	the majority
la moitié	half
nombreux	many
pas mal de	quite a few
peu	not much
Presque	almost
quelques	some
tout / toute /	all
tous / toutes	
un quart	a quarter
un tiers	a third

4. PALMO

How to describe a photo

P eople
A ction
L ocation
M ood
O pinion
Dans la photo il y a personnes
Ils sont en train de + infinitive
La scène se déroule
Ils ont l'air.....
J'aime/ je n'aime pas parce que

5. PROTECTING THE PLANET

On pourrait/ on devrait ...	We could/ should ...
trier les déchets	separate rubbish
consommer moins d'énergie	use less energy
éteindre la lumière et les	turn off lights and
appareils électriques	electrical appliances
mettre un pull au lieu d'allumer le	put on a jumper instead
chauffage	of the heating
acheter des produits verts	buy green products
voyager autrement	travel differently
utiliser les transports en commun	use public transport
économiser de l'eau	save water
installer les panneaux solaires	install solar panels

6. INTERESTS & CONCERNS

Ce qui est important pour	What's important for me is
moi, c'est
l'argent	money
ma santé	my health
Ce qui me préoccupe, c'est	What concerns me is ...
l'environnement	the environment
l'état de la planète	the state of the planet
le racisme	racism
la cruauté envers les	cruelty against animals
animaux	
la faim	hunger
la guerre	war
l'injustice	injustice
la pauvreté	poverty



KNOW IT

1. Translate: The most important thing to me is my family.
2. Translate: I recycle.
3. Translate: the thing that worries me the most is the environment.
4. Translate: it's important that you recycle
5. Translate: I don't waste water
6. Translate: You must shower instead of having a bath (use au lieu de)
7. Translate: you should help developing countries
8. Translate: You can do charity work.
9. Write a sentence explaining what is important to you in life.
10. Write down two things that worry you.

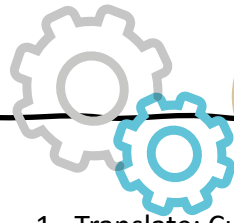

THINK IT

1. Translate: Currently I do quite a lot to protect the environment.
2. Translate: If I had the time I could separate the rubbish.
3. Translate: Everyone should go to school by bike.
4. Translate: You must use public transport.
5. Write a sentence explaining what you could / should do to help the environment.
6. Translate: Volunteering makes me feel more confident.
7. Translate: It's important to participate in society.
8. Change question 1 and 2 into the third person singular (he / she)
9. Translate: An advantage of this event is that it increases national pride.
10. Give a disadvantage of the Olympics.

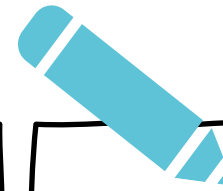

GRASP IT

1. Create three sentences in the conditional about what you could do to protect the environment more. Use a different sentence starter each time.
2. Give two reasons as to why volunteering is important.
3. Give an advantage and a disadvantage of a world event.
4. How many ways do you know to introduce an argument?
5. Give three ways of introducing the other side of the argument.
6. Write down 10 key verbs linked to this topic.
7. Create 2 negative sentences to say what you don't currently do to help the environment using ne jamais/ nepas
8. Prepare a 30 second presentation to highlight the pros and cons of a world event of your choice.
9. Décris la photo. Use PALMO

Geography: Fieldwork

1. Stages of a fieldwork project

1. Question / Hypothesis – Has the regeneration of Birmingham been successful ?
2. Data Collection - How did we collect the data ?
3. Data Presentation – What is the most suitable way to present the data ?
4. Data Analysis - What is the data telling us ?
5. Conclusion – The regeneration of Birmingham HAS been successful.
6. Evaluation – How could we improve the reliability of the data that we have collected ?

4. Types of Data

Primary Data	Data that is collected in the field	Pedestrian count
Secondary Data	Data that has been collected by someone else	Crime statistics of an area
Quantitative Data	Numerical data	Traffic count
Qualitative Data	Opinion based data	Questionnaires

2. Risk Assessment

This is where you consider what could cause people harm while completing fieldwork and think about how to reduce the likelihood of this happening.

Types of Risks

Slips, trips and falls – wearing appropriate footwear.

Getting lost - working in groups and making sure.

Traffic accidents – Ensuring all students are behaving sensibly when collecting data.

5. Sampling Techniques

Random sampling	The data is collected at random
Systematic sampling	The data is collected using a system
Stratified sampling	Selecting an area of group that you need to collect data from

3. WOW Words

1. **Reliability** - The extent to which an investigation produced consistent results. (If you do it again, would you get the same results?)
2. **Limitations** – Issues with the reliability of collecting the data
3. **Anomalies** - A result that is unusual or does not follow the trend of the other data.
4. **Sample size** – The number of measurements that you have collected e.g. 100 questionnaire results.

6. Conclusion and Evaluation

Improve your methods - Is there better equipment you could have used? Should you have used a different sampling method?

Improve the reliability of your results - Increase your sample size. Collect data at different times of the day or days of the week.

Improve the accuracy of your results - Use digital fieldwork equipment. Take measurements 3 times and take an average



KNOW IT

1. Write an enquiry question for a fieldwork topic.
2. Why is a large sample size important when collecting data ?
3. What is random sampling
4. What is systematic sampling ?
5. What is stratified sampling ?
6. Name 3 ways to present data.
7. What is qualitative data ?
8. What is quantitative data ?
9. What is anomalous data ?
10. Why is accuracy important in collecting data ?

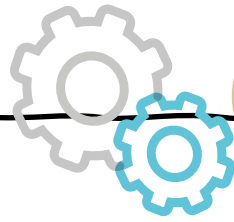

THINK IT

1. Explain why collecting primary and secondary data is important in a fieldwork project.
2. Explain how questionnaires can help to judge whether the regeneration of Birmingham has been successful or not.
3. Give three qualitative techniques to collect data.
4. Give three quantitative techniques to collect data.
5. How is it possible to make data collected more reliable ? What could be done better ?

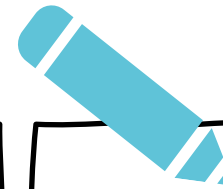

GRASP IT

1. Explain why Birmingham city centre is a suitable location to investigate urban regeneration.
2. You have been asked to complete a risk assessment for a fieldwork trip at the coast. Outline the risks and the control measures for this trip.
3. You been asked to collect data on how the size and shape of sediment changes downstream in a river. How would you collect this data ?
4. Explain why the Evaluation section of a fieldwork project is important ?
5. How far do you agree that the regeneration of Birmingham has been successful ?

History: Elizabethan England

1. Religion

Elizabeth was **Protestant** but inherited the upheaval of the **Reformation** and her families. She tried to compromise with her 'religious settlement'. This included priests could marry, book of common prayer and she declared herself **governor**. The Pope in reaction **excommunicated** Elizabeth and Catholics were encouraged to rise up against her. **Jesuits** were sent to convert Protestants back to Catholic. This was punishable by death.

4. WOW WORDS

Middle Way: Elizabeth's religious policy to bring peace.
Armada: The fleet of Spanish ships used to invade England.
Walsingham: Elizabeth's spy master and close advisor.
Jesuit: Catholic priest used to convert Protestants to Catholic.

2. Mary Queen of Scots

MQS was brought up in France, when she returned to Scotland in 1560 she was very unpopular and fled to England in **1567**. Mary was placed under **house arrest** and was moved around England for **19 years**. Mary was the legitimate heir to the English throne and was **Catholic**, this made her a threat to the childless Elizabeth. Several plots planned to put her on the throne but during the **Babington Plot Walsingham** found evidence that she knew of the plot. Mary was put on trial in October 1586 and **found guilty of treason** even though she argued that as she was not English and a Queen they had not right. On 8 February **1587 Mary was executed** at Fotheringhay Castle making her a **martyr**.

5. Conflict with Spain

Causes: Philip had been married to Mary Tudor and wanted England to be Catholic again, Elizabeth had refused his marriage proposal and sent troops to rebel against Spain.
Failure: The Armada failed because of poor tactics by the Spanish including having a seasick main in charge, Duke Medina Sidonia. The English tactics including the use of fire ships was ingenious in defeating the Spanish. This was then followed by terrible storms that wrecked many of the Spanish ships on their way back round Scotland.

3. Key Events

1567	Mary Queen of Scots comes to England.
1569	The Northern Rebellion
27/4/1570	Pope Pius V issued the Papal Bull and excommunicated
1571	The Ridolfi Plot. Recusancy fines.
1581	Treason to attend Catholic mass. Recusancy fines increased.
1583	The Throckmorton Plot. Rules to crack down on Puritanism.
1585	Treason to have a Catholic priest in your home. Act against Jesuits and Seminary Priests
1586	The Babington Plot. Mary Queen of Scots put on trial.
8/2/1587	Mary Queen of Scots executed.
1588	The Spanish Armada
1593	Statute of Confinement - Catholics could not travel more than five miles from home.



KNOW IT

1. What was Elizabeth's religious settlement?
2. How did Elizabeth try to please the protestants?
3. Why was MQS seen as a threat?
4. What plot caused MQS execution?
5. Who helped find the evidence which led to MQS execution?
6. Why was there tension between England and Spain?
7. What caused the Spanish Armada to fail?

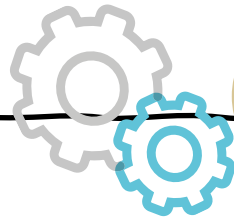

THINK IT

Interpretation A – *An assessment of the threats to Queen Elizabeth from The Life and Times of Elizabeth I*, by Neville Williams (1972)

'There were other plots against Elizabeth's life in later years. However the revelations of the Ridolfi conspiracy, coming so soon after the Northern Rebellion, alarmed her the most. That her own cousin, the Duke of Norfolk, should have plotted her downfall was the cruellest blow she had yet suffered.'

Who was responsible for the Ridolfi Plot?

Why was Elizabeth so shocked about the Ridolfi Plot?

What similarities can you see between the Ridolfi and the Babington plot?

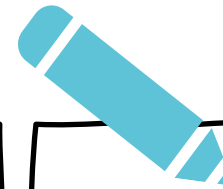

GRASP IT

Explain what was important about the execution of Mary Queen of Scots for those in Elizabethan England. 8 marks.

Write an account of Elizabeth's changing attitude towards Catholics. 8 marks.

Explain what was important about the Navy for Elizabethan England. 8 marks.

Hospitality and Catering: Types of Provision

1. Hotel and Guest House Standards

Hotels and guest houses standards are awarded and given star ratings. You should know what criteria is needed to be met for an establishment to receive each star rating.



Ratings between one and five rosettes could be awarded based on the following:

- different types and variety of foods offered
- quality of the ingredients used
- where the ingredients are sourced
- how the food is cooked, presented and tastes
- skill level and techniques used as well as the creativity of the chef.

Coveted by many chefs but bestowed upon only to an excellent few.
Getting a star (or three) could change the fate of a restaurant.

 High quality cooking, worth a stop	 Excellent cooking, worth a detour	 Exceptional cuisine, worth a special journey
---	--	---

Good Food Guide

A rating between one and 10 could be awarded based on the following:

- cooking skills
- quality of ingredients
- techniques and cooking skills shown.

2. Commercial and Non-Commercial

Commercial (non-residential) catering establishment that aim to make a profit from their service, but no accommodation is provided.

Non-commercial (residential): the hospitality and catering provision offers accommodation but does not aim to make a profit from the service they provide.

Commercial (non-residential) catering establishments that aim to make a profit from their service, but no accommodation is provided.

Non-commercial (non-residential): catering establishments with no accommodation provided and don't aim to make a profit from their service.

3. Types of Service

The different types of food services in the catering sector. You should know the meaning of each one and be able to provide examples. For instance;

Table service

- **Plate:** the food is put on plates in the kitchen and served by waiting staff. Good portion control and food presentation consistent. Sliver service is when the food is served to you using a spoon and fork.

Different types of residential types of service in the hospitality and catering sector. You should know the different types of service offered in various hospitality provisions.

Rooms:

- single/ double/ king/ family
- suite (en-suite bath/ shower room, shared facilities).

Refreshments:

- breakfast/ lunch/ evening meal
- 24-hour room service/ restaurant available.

4. Food Poisoning Bacteria

The main causes of food poisoning bacteria are:

- **Bacillus cereus:** found in reheated rice and other starchy foods.
- **Campylobacter:** found in raw and undercooked poultry and meat and unpasteurised milk.
- **Clostridium perfringens:** found in human and animal intestines and raw poultry and meat.
- **E-coli:** found in raw meat, especially mince.
- **Listeria:** found in polluted water and unwashed fruit and vegetables.
- **Salmonella:** found in raw meat, poultry and eggs.
- **Staphylococcus aureus:** found in human nose and mouth.

Food can cause ill-health if it is stored, prepared and/or cooked incorrectly or if a person unknowingly eats a food that they are allergic or intolerant to. All hospitality and catering provision need to follow laws that ensure food is safe to eat.

You need to know the following types of employment contracts and working hours.

- **Casual:** Zero contract, there is no sick pay or holiday entitlement with this type of employment.
- **Full time (permanent):** Works 5 days, a contract of this nature allows the employee to have sick pay and holiday entitlement.
- **Part-time (permanent):** Works 3 days, has sick pay and holiday entitlement in this type of contact.
- **Seasonal:** this type of contract is used when a business needs more staff due to busy times throughout the year, such as the Christmas period.
- **Zero hours contract:** Work only when business requires, no sick pay or holiday entitlement is offered for this type of contract.

Hospitality and Catering: Health and Safety

5. Food Hazards

A food hazard is something that makes food unfit or unsafe to eat that could cause harm or illness to the consumer. There are three main types of food safety hazards:

- Chemical – from substances or chemical contamination e.g. cleaning products.
- Physical – objects in food e.g. metal or plastic.
- Microbiological – harmful bacteria e.g. bacterial food poisoning such as Salmonella.

7. Environmental Health Officer (EHO)

The EHO can carry out an inspection of any hospitality and catering premise at any time during business hours – they do not need to make an appointment. During an inspection, the EHO will check to make sure that:

- the premises are clean
- equipment is safe to use
- pest control measures are in place
- waste is disposed properly
- all food handlers have had food hygiene and safety training
- all food is stored and cooked correctly
- all food has best-before and use-by dates
- there is a HACCP plan to control food hazards and risks.

6. Environmental Issues

The 3 R's
The chef will need to think about environmental issues when planning a menu. Can the chef reduce the amount of ingredients bought as well as reducing food waste? Can the chef reuse ingredients to create new dishes for example stale bread made into bread-and-butter pudding? Can the kitchen recycle waste wherever possible? Running the kitchen sustainably will save money. The above will also need to be considered for front of house how to reduce plastic and waste.

8. HACCP- Hazard Analysis Critical Control Point

Every food business lawfully needs to ensure the health and safety of customers whilst visiting their establishment. To ensure this, they need to take reasonable measures to avoid risks to health. HACCP is a food safety management system which is used in businesses to ensure dangers and risks are noted and how to avoid them.

Hazard		Critical control Point
Receipt of food	Food items damaged when delivered / perishable food items are at room temperature / frozen food that is thawed on delivery.	Check that the temperature of high-risk foods are between 0°C and 5°C and frozen are between -18°C and -22°C. Refuse any items that are not up to standard.
Food storage (dried/chilled/frozen)	Food poisoning / cross contamination / named food hazards / stored incorrectly or incorrect temperature / out of date foods.	Keep high-risk foods on correct shelf in fridge. Stock rotation – FIFO. Log temperatures regularly.
Food preparation	Growth of food poisoning in food preparation area / cross contamination of ready to eat and high-risk foods / using out of date food.	Use colour coded chopping boards. Wash hands to prevent cross-contamination. Check dates of food regularly. Mark dates on containers.
Cooking foods	Contamination of physical / microbiological and chemical such as hair, bleach, blood etc. High risk foods may not be cooked properly.	Good personal hygiene and wearing no jewellery. Use a food probe to check core temperature is 75°C. Surface area & equipment cleaned properly.
Serving food	Hot foods not being held at correct temperature / foods being held too long and risk of food poisoning. Physical / cross-contamination from servers.	Keep food hot at 63°C for no more than 2 hours. Make sure staff serve with colour coded tongs or different spoons to handle food. Cold food served at 5°C or below. Food covered when needed.

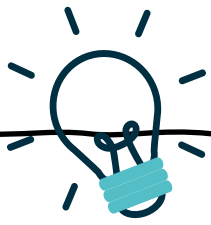

KNOW IT

1. Define how hotels and B & B's are rated
2. Define the term food service.
3. What are the different job roles within the hospitality and catering industry?
4. What is the difference between commercial and non commercial?
5. What is the difference between commercial residential and non commercial non residential?
6. What are the 3 R's?
7. What types of contracts are available in the hospitality and catering sector?
8. What hazards need to be considered when preparing food?
9. What rating does the Environmental Health Officer give to food premises?
10. Define food poisoning.
11. Define HACCP.

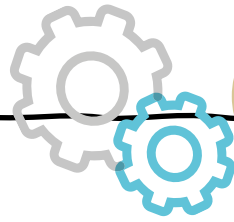

THINK IT

1. Explain what the ratings are and what would you expect in a 5* hotel.
2. Explain the different food services that are available and what factors need to be considered.
3. Explain the different roles within hospitality and catering establishments.
4. Explain what establishments come under commercial and non-commercial.
5. Explain how establishments can reduce waste.
6. Give examples of what type of contract to have depending on your age.
7. Give examples of good food hygiene practices.
8. Explain why it is important that food premises are inspected.
9. Explain what the EHO will look for when they inspect premises.
10. Give examples of different types of food poisoning.
11. Complete a HACCP table for safe preparation for spaghetti bolognese.

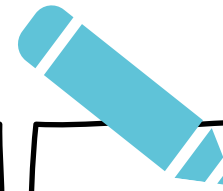

GRASP IT

1. Make a list of the items that you would expect to find in a room when staying in a hotel. What else can be added to make it 5*.
2. Consider a café in your local area, how do the staff speak to you, what are they wearing, can you identify the staff easily, what type of service do they operate.
3. Consider the environment and how establishments can reduce the carbon footprint.
4. Why is it important that employees are given a contract?
5. Explain what hospitality and catering means.
6. Why should chefs use foods that are in season.
7. Explain what powers the EHO have.
8. How can premises improve their hygiene rating?

Year 11

Hospitality and Catering

Provision. Health and Safety

Media Studies: Key Theories Audiences

1. Uses & Gratification Theory

The theory suggests that consumers use media products for at least one of these reasons:

Identity – , share similar values to, etc.

Educate – to learn new things.

Entertain - to be entertained a form of 'escapism'

Social Interaction –allows for conversation between other people

2. Propp's Character Theory

Propp suggested that every narrative has eight different character types, these character types are:

- The hero**— Main charact on the quest.
- The villain** — fights the hero in some way.
- The dispatcher** — send hero on mission.
- The helper** — helps the hero in the quest.
- The princess or prize** —object of the quest.
- The father** — gives the task to the hero.
- The donor** — prepares the hero or gives the hero some.
- The false hero** — takes credit for the hero's actions

5. Todorov's Narrative Theory

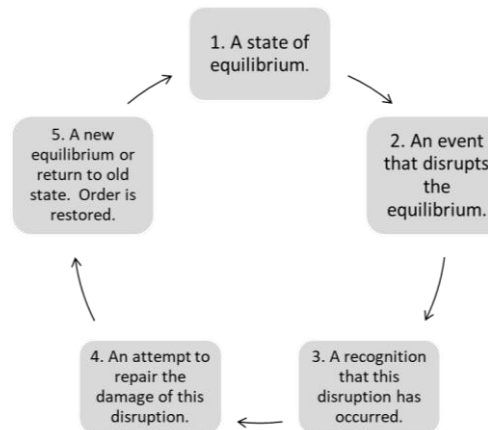

4. Hypodermic Needle Theory

The media injects ideas and views into the brains of the audience therefore controlling the way that people think and behave. People are often seen as passive.

3. WOW WORDS

Denotations = what you can see

Connotations = What is suggested or implied

Representation = People, Places & Idea

Intertextuality = When one type of media reference another

Camera Angles & types of shots = Refer to your book for the full list

Enigma Code = A question posed which encourages people to watch.

6. Stuard Hall's Reception Theory



Preferred reading

The audience responds in exactly the way the media producer wants them to.



Negotiated reading

Where the audience compromises between the producers intended reading and their own opinions and preferred reading of media text.



Oppositional or resistant readings

The audience rejects the meaning or intended reading of the media product.



KNOW IT

1. Why an audience consumes a product? (Gratification Theory)
2. The different types of characters (Propp's)
3. The 5 parts of Gratification Theory
4. Audience Reception Theory – Preferred reading, Negotiated reading and oppositional reading

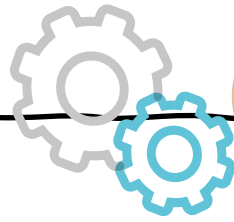

THINK IT

1. Why do some audiences consume products for different reasons? (An adult might go to the cinema to socially interact with others, rather than a child that would go for entertainment.)
2. My might a 'hero' character be different when considered over a series to an individual episode?
3. Why might there be several 'disruptions' in a storyline?

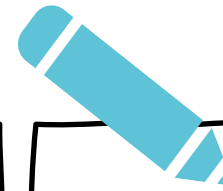

GRASP IT

- What are the pleasures and rewards for music video audiences? (Gratification Theory)
- How has technology enabled self-production of music?
Explain how camerawork, sound and editing make meanings in the extract from His Dark Materials, The City of Magpies.
- How does Kim Kardashian Hollywood converge various parts of the Kardashian brand and why?

Magazines : Front cover of *Tatler*, January 2021 / Front cover of *Heat*, 21-27 November 2020
Advertising & marketing: Galaxy TV ad (2014) / NHS Blood online / OMO Print ad
Newspapers: *Daily Mirror* – Newspaper **Edition**: Friday 5 March 2021 / *The Times* - Newspaper **Edition**: Friday 5 March 2021
Online, social and participatory media: Product: Marcus Rashford / Kim Kardashian
Video Games: Kim Kardashian – *Hollywood* / Lara Croft – *Go*
Radio: Radio 1 Launch Day / Kiss Breakfast on KISS Radio
Music video: Arctic Monkeys – *Bet you look good on the dance floor* (2005) / Blackpink – *How You Like That* (2020)
Film: *Black Widow* / *I*, Daniel Blake
Television* **Section A Media 2**: *His Dark Materials* (2020) BBC TV Series. **Series 2, Episode 1: The City of Magpies** / *Dr Who*, **Series 1, Episode 1 An Unearthly Child** (1963)

Photography: Contrasts

1. Composition

Composition

Composition is the way the different elements within a scene are placed within the frame of a photograph.

Compositional devices

- Rule of thirds
- Foreground interest and depth
- Leading lines
- Diagonals and triangles
- Rule of odds

2. Experimentation

Experimentation

Chose a free app e.g snapseed, photopea, befunky or pixlr and create 10 edits using the different functions in the app. Be sure to explore vignette, double exposure, white balance and black & white. Save your edits. How can your edits link to your research?

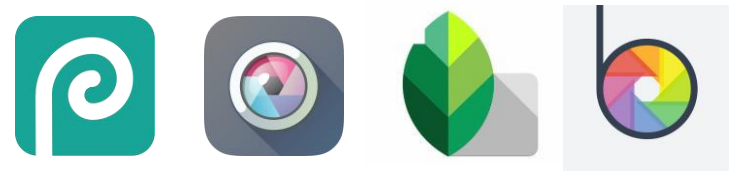

3. WOW WORDS

- Pattern
- Evoke
- Mood
- Feeling
- Portray
- Texture
- Symmetry
- Asymmetry
- Scale
- Balance
- Depth of field
- Angular
- Organic
- Lines
- Curves
- Contrast
- Viewpoint
- Negative space
- Filled space
- Distort
- Express
- Foreground
- Background
- Visual tension

4. Aperture

Aperture

Aperture is an opening which light travels through. Aperture controls the brightness in a photographic image and it is expressed as an f number.

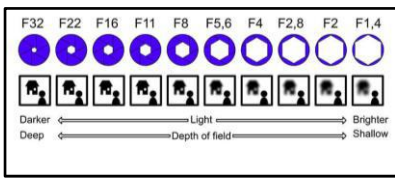

5. Shutter speed

Shutter speed

Shutter speed is the length of time the digital sensor or film is exposed to light.

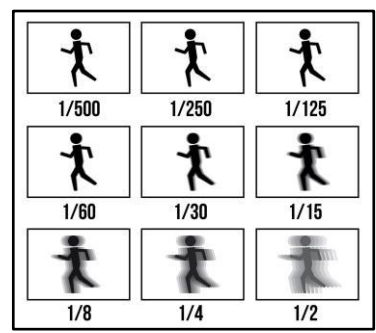

6. Photographer inspiration

Photographers

Look at the work of others for inspiration.

- Andre Kertesz
- Malick Kebe
- Jason Gaskins
- Edward Weston



Other Photographers

- Olafur Eliasson
- Sven Pfommer
- Bill Armstrong





KNOW IT

Composition is the way the different elements within a scene are placed within the frame of a photograph.

Explore by gathering information for research and inspiration. Research using books, the internet, magazines and remember to record where the information is taken from. Look at artists that have based their work on similar themes.

Selects a range of photographers to inspire you. Use box 3 on this knowledge organiser to guide you or research your own by exploring artists on the internet, in books or magazines.

Identify the key features of a photographers work. Identify the characteristics of the artists style/techniques. Find out key facts about the artist. Create a visual study if the artists work.

Create design developments that show clear inspiration to the artists work as well as incorporating your own ideas.

Realise your intentions in a final outcome that shows refinement and development from your design ideas.

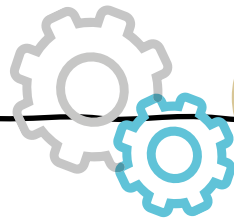

THINK IT

How does using composition impact the visual quality of your photograph? Name 5 compositional devices.

Research and analyse the work an photographer. How can a photographer inspire you? How can you link your work to your chosen photographer?

Recording of ideas – have you selected appropriate source material? (images, photographs etc) How will you present this in your visual mind map as an introduction for your project?

Have you developed your observational awareness skills by taking a range of photographs that show your ideas and that make links to your photographers?

Have you made links to your selected photographer? How does this show in your design developments?

Have you refined your work? How have your made visual improvements?

Is your work throughout your portfolio consistent with the visual quality and the connections to your ideas?

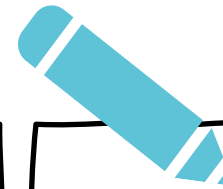

GRASP IT

Take a set of 10 photographs for your portfolio that uses the compositional device rule of thirds and 10 that use full frame

Evaluate your strengths and improvements. What are the strengths in your work? Why do you think that? Did you identify any problems? How did you solve them? Were you able to fully realise your intentions? Why or why not? How could you further develop your ideas?

Create a series of 10 digital edits outside of lessons using your mobile phone and a free app such as those suggested in box 2. Print your work off in school and add to your portfolio to show further experimentation, development and refinement.

Create 10 physical experiments that explore shape and colour. Cutting shapes out from your photographs and layering them together. Find a photographer to make links to this experimentation.

Year 11

Photography

Contrasts

Physical Education: Volleyball

Part One

Rules & Regulations

- ❑ An official volleyball court is 18 m × 9 m.
- ❑ To start a point, the server can serve from anywhere behind the end line, either overarm or underarm, into the opposing team's side of the court.
- ❑ The opposing team is allowed a maximum of three touches on their side of the court before sending the ball back over the net.
- ❑ A player is not allowed to touch the ball twice in a row. However, they could hit the ball on the first and third contact.
- ❑ The ball must be hit - not caught.
- ❑ In side out scoring, the serving team scores a point when the opponents fail to return the ball over the net, hit the ball out of bounds or commit an infraction.
- ❑ Whichever team wins the point then goes on to serve.
- ❑ Every time a team wins the serve from the other team, the players rotate their position on court clockwise so that everyone gets a chance to serve

Player Positions

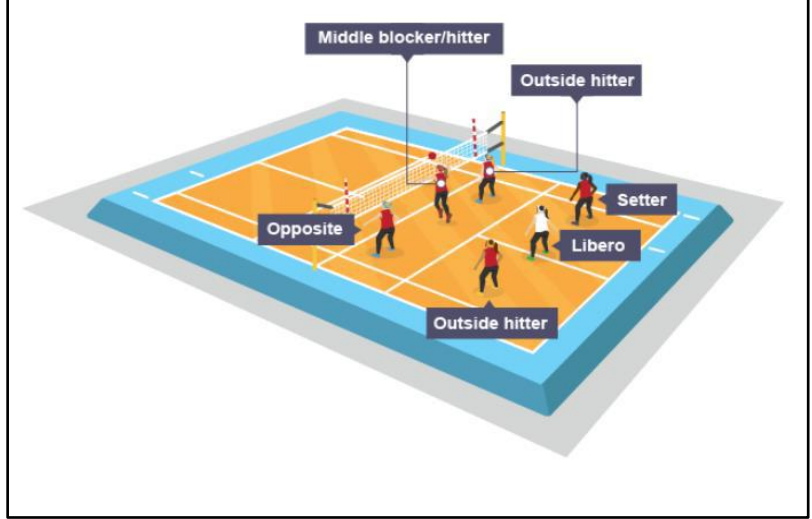

Officials

A first (or main) referee, second referee, a scorer and two line judges are required to umpire an official game of volleyball. Just like most sports, the main referee upholds the rules throughout the whole game and their decision is final.

However, unlike football, a volleyball team is allowed to make a formal protest with the scorer. The second referee stands opposite the main referee and is responsible for all substitutions, timeouts and the actions of the scorer's table.

Wow words

Dig	Setter	Libero
Blocker	Centre line	
Service line	Out of bounds	

Scoring

In competitive adult matches all games are played to a best of five sets.

Volleyball is very different to most sports as the first four sets are played to 25 points, but if the match goes to a fifth set this game is only played to 15 points.

In order to win a set, a team must win by two clear points.

Court Dimensions

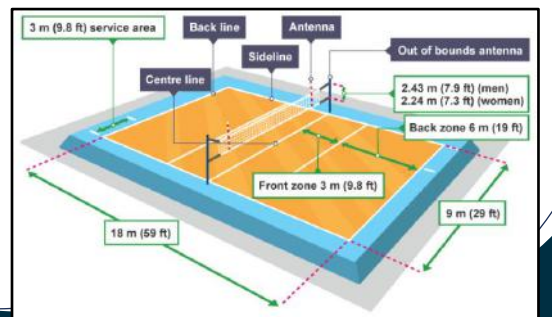

Physical Education: Volleyball

Part Two

Volleyball – Serve, Dig, Set & Block

Serve



A volleyball serve can be hit either overarm or underarm. A player is allowed to travel with the ball and jump whilst serving, and providing it reaches the opponent's court, it is deemed legal.

Stage one

Stand in position on the balls of your feet, with knees slightly flexed. Face forwards with your chest facing towards the target. Hold the ball in front of your body with left hand, right hand held back. Body weight should be on the back foot.

Stage two

Throw the ball gently into the air, swing the straight arm forward to strike underneath the ball with the heel of the hand, with your fingers clenched. Transfer bodyweight from back to front foot.

Stage three

Follow through with the fist pointing towards the intended target or the sky.

Dig



The dig shot requires players to get low and to stop the ball touching the ground. When completed successfully the shot provides accurate and consistent passing, which is essential to create a multiple attack.

Stage one

Stand in position on the balls of both feet, with knees slightly flexed. Drive off from legs to get towards the path of the ball.

Stage two

Keep both eyes on the ball. Place the back of the right hand on top of the palm of the left hand. Bring both thumbs together and place them side by side. Keep fingers and thumbs close together. Lock your elbows together. Hold arms out straight in front.

Stage three

Hands start low in front of the body and swing up to strike the ball upwards. Strike the ball with the lower forearms. Follow through with the hands pointing towards the intended target or the sky.

Set



The set shot is a delicate attacking shot that is an important part of the pass-set-spike sequence required for a successful attack.

Stage one

Stand in position on the balls of your feet, with knees slightly flexed. Drive off from legs to get towards the path of the ball. Call for the ball. Get in line with the ball's path. Keep your eyes on the ball at all times.

Stage two

Move towards the ball. Extend your elbows so that your arms are out in front of you at head height. Slightly flex your elbows. Have your palms facing up and fingers spread. Keep your eyes on the ball.

Stage three

Watch the ball. Face the ball in ready position with knees slightly flexed. Hands are held above the head, palms up. Move body underneath the ball and push the ball into the air with your fingertips. Extend knees to help with the push into the air. Follow through with fingers pointing at the sky.

Block



The block is not technically a maintaining possession shot, but a well-timed and effective block diffuses an offensive attack.

Stage one

Stand in position on the balls of your feet, with knees slightly flexed. Drive off from legs to get towards the path of the ball. Get in line with the ball's path. Keep your eyes on the ball at all times.

Stage two

Move towards the ball. Extend arms up above head. Have your palms facing forward and fingers spread. Keep your eyes on the ball.

Stage three

Upon contact, try to angle the ball downwards. Begin to land move arms outwards for balance. Flex knees to help cushion landing. Get back into position to regain formation.



KNOW IT

Technical

1. How do I serve?
2. How should I dig the ball?
3. How can I attack space effectively?
4. What methods can I use to score a point?
5. How do I set?
6. What is the role of a libero?

Health, Fitness & Well-Being

7. How can exercise help my well-being?
8. Why do we warm up?
9. How can I train for this sport?
10. What are the principles of training?

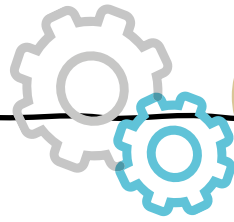

THINK IT

Technical

1. What type of serve is most appropriate?
2. Describe three things a player can do when in possession of the ball.
3. Why is attacking space important?
4. Where should you aim when at the net?
5. Give an example of defending.

Health, Fitness & Well-Being

6. What mental benefits do you get out of playing invasion games?
7. What 3 components of a warm-up should be used?
8. How will this develop my body to give me an advantage?
9. How can they be applied to your training?

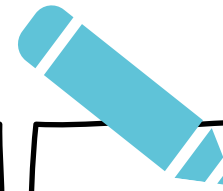

GRASP IT

Technical

1. Why is it important to use appropriate power?
2. How can the dig or set be used to receive the ball in a game situation?
3. What are your three main shots when you receive the ball?
4. Explain how to score a game as an official.
5. Who serves & how do you know?

Health, Fitness & Well-Being

6. How do you think sport will help you at school?
7. Create a warm-up plan for you to use before a competitive match.
8. Why is muscular endurance a benefit for invasion sports?
9. What will happen to my body if I keep overloading my training?

Year 11

Physical Education

Volleyball

Physical Education: Netball



1. KEY SKILLS

- **Passing and receiving** – different types of passes include chest pass, bounce pass, shoulder pass and overhead pass.
- **Attacking** – getting free from an opponent in order to receive the ball. Includes the skills of sprinting, dodging and changing direction.
- **Shooting** – With one hand under the ball and the other steadying it at the side, keep your eyes on the hoop, bend your knees and push the ball with the fingers.
- **Defending** – Marking your opposite player both with and without the ball.
- **Footwork** – You must land with a 1-2 landing or with 2 feet. You must then not move the landing foot.
- **Holding space** – trying to keep space in which to receive a pass. Especially useful in the circle.

2. COURT & POSITIONS

Netball Positions: (and who they mark)

Goal Shooter- allowed in the shooting third only (GK)

Goal Attack- allowed in the shooting and centre third (GD)

Wing Attack- allowed in the centre and shooting third but not the circle(WD)

Centre- allowed everywhere except the 2 circles (C)

Wing Defence - allowed in the centre and defending third but not the circle (WA)

Goal Defence- allowed in the defending third and the centre third (GA)

Goal Keeper- allowed in the defending third only. (GS)

4. COACHING SHOOTING

- Feet shoulder width apart facing the post.
- Ball held high directly ABOVE your head.
- Knees and elbows are slightly bent to push off.
- Eyes looking at a point above the ring.
- Flick the ball upwards using wrist and index finger

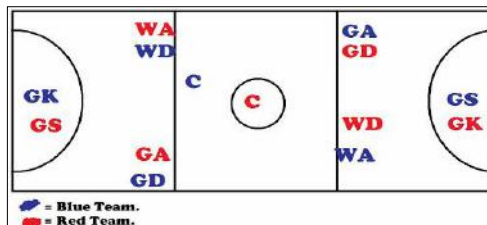

3. WOW WORDS

- | | |
|--------------|---------------------|
| Passing | Offside |
| Contact | Pivot |
| Defence | Replaying the ball |
| Dodging | Shoulder pass |
| Footwork | Change of direction |
| Held Ball | Marking |
| Interception | Obstruction |

Landing



5. COACHING DEFENDING

Stage 1. Mark the player they haven't got the ball yet but you can still man-mark them.

Stage 2. Your player's received the ball and now you're up close to make life difficult for them.

Stage 3. You're marking the space – anticipating the pass and preparing to drive in front to snatch it away

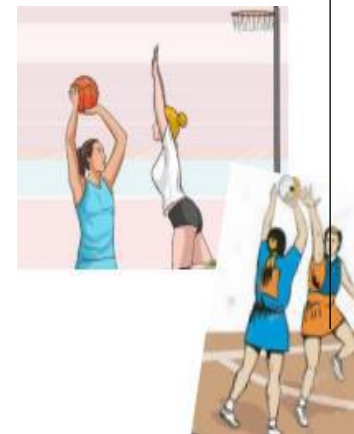



KNOW IT

Technical

1. What are the three types of pass?
2. How can I receive the ball?
3. How can I attack space effectively?
4. What players can I use to score?
5. What are the 7 positions in a team?

Health, Fitness & Well-Being

6. How can running help improve my well-being?
7. How do we warm up for netball?
8. What physical benefits does a warm-up bring?
9. How can I train for invasion sports, like netball?
10. What are the principles of training?

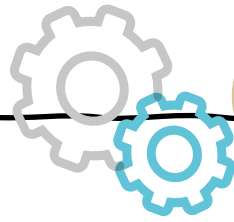

THINK IT

Technical

1. When should each type of pass be used?
2. Describe the players positions and what their roles are in the team.
3. Why is attacking space important?
4. What order of play should you go through? Start from the GK. Why?
5. Give an example of creating space for your position.

Health, Fitness & Well-Being

6. What benefits do you get out of playing invasion games like netball?
7. What 3 components of a warm-up should be used?
8. How will this develop your body to gain an advantage in netball?
9. How can this be applied to your game?
10. What is your favourite position & why?

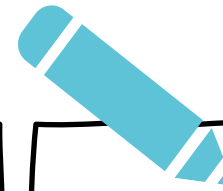

GRASP IT

Technical

1. Why is it important to give a pass appropriate accuracy and power?
2. How can footwork & pivoting help receive the ball in a game situation?
3. Who restarts from a centre pass? How do you know?
4. Explain what is meant by the term replaying/repossession
5. Why do GS need to be good creating space in the game?

Health, Fitness & Well-Being

6. How do you think this sport will help you at school?
7. Create a warm-up plan for you to use before a competitive match.
8. Why is muscular endurance a benefit for invasion sports?
9. What will happen to your understanding if you play in all the different positions?



Netball

GCSE Physical Education: Paper One

Skeletal System

- Structure & function of the skeleton
- Types of bones classification
- Structure of a synovial joint
- Types & locations of hinge, ball & socket joints.

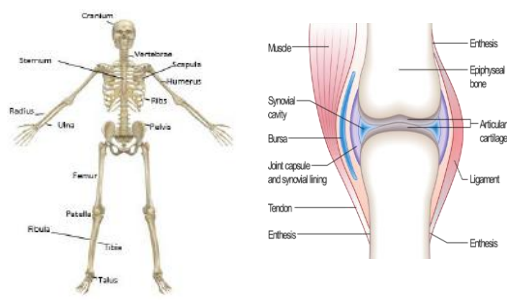

Muscular System

- Names & location of key muscles
- Role of each muscle
- Antagonistic muscle pairs
- Connective tissues
- Types of muscle contraction

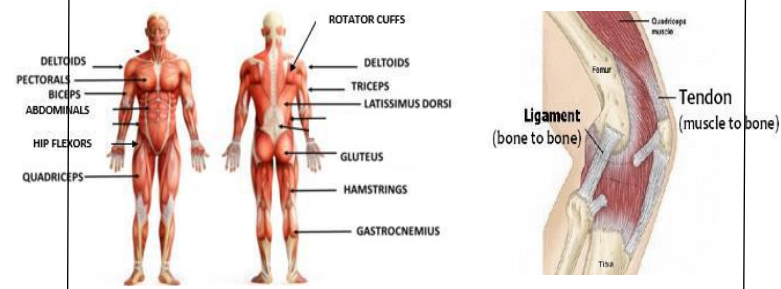

Respiratory System

- Mechanics of breathing
- Gaseous exchange process
- Aerobic & anaerobic respiration
- Lung volumes & a spirometer trace

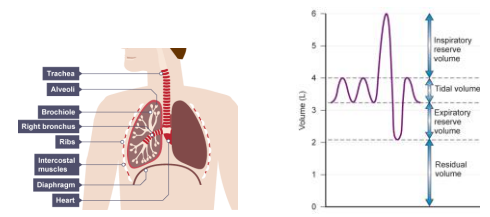

Movement Analysis

- Classification of lever systems.
- Components of a lever system & movements within human body.
- Types of movement
- Planes of motion & sporting examples.
- Axes of rotation & sporting examples

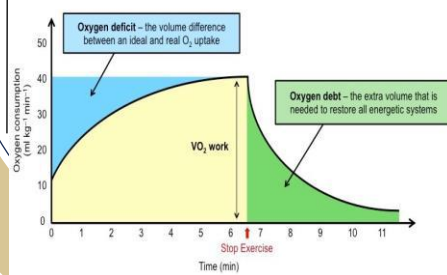

Cardiac system

- Labelling the cardiac system
- Structure & function of blood vessels
- The cardiac cycle
- Vascular shunt mechanism & blood redistribution

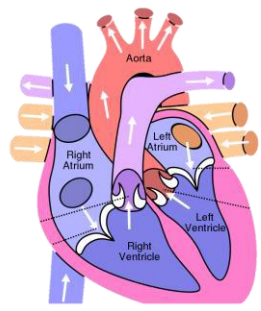
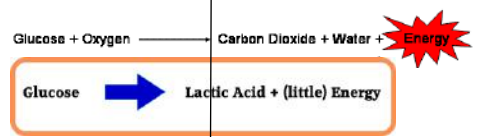

Physical training

- Components of fitness
- Principles of training
- Exercise intensity & training zones
- Methods of training
- Seasonal training
- Preventing injuries
- Warming up & cooling down

Use of data

Types of data
Analysing & interpreting data

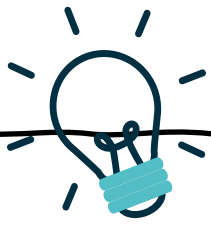

KNOW IT

1. State the 15 main bones.
2. Recall the four classification of bone
3. Describe the key functions of the skeleton.
4. Label a synovial joint image
5. State the 13 main muscles.
6. What are the 3 types of muscle contraction
7. Label the pathway of air.
8. Label an image of the heart.

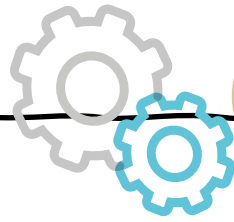

THINK IT

1. Explain the role of each bone classification.
2. For each function of the skeleton name a bone which matches this.
3. Where are the main synovial joints in the body?
4. Describe the role/purpose of each muscle.
5. Describe the pathway of air.
6. State the order of the cardiac cycle.

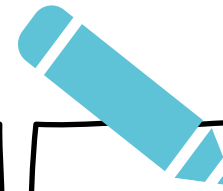

GRASP IT

1. Give an example of how a particular bone allows a sporting movement to take place.
2. Describe a sporting action for each bone classification.
3. Analyse how each joint allows a certain type of bodily movement.
4. Explain examples of each type of muscle contraction.
5. Explain the process of gaseous exchange.

Year 11

GCSE Physical Education

Paper One

GCSE Physical Education: Paper Two

Skill Classification & Information Processing

- Place skills on continuums including;
 - Open to Closed
 - Basic to Complex
 - Self paced to externally paced
 - Fine movements to Gross movement
- Explain the information processing model stages (below image)



Social groups & engagement factors

- Factors which affect participation in sport & physical activity, including;
 - Age
 - Gender
 - Ethnicity & religion
 - Friends, family & peer
 - Disability

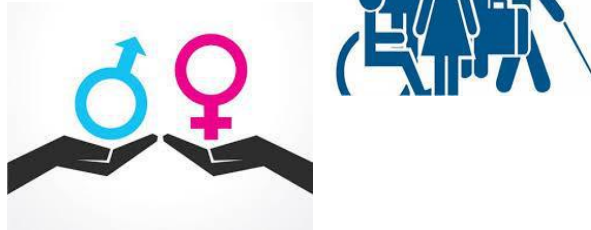

Health, fitness & well-being

- Physical, fitness, mental & social benefits to participating in physical activity
- Sedentary lifestyles, obesity & related diseases.
- Body somatotypes



Guidance, goal setting & types of feedback

- Explain the 4 main types of guidance a coach might use to help performers.
- Explain the 6 types of feedback a coach can use for performers.
- Describe the two types of goals that can be set & SMART factors.



Performance Enhancing Drugs, Player & Spectator Conduct

- 7 main groupings of PEDs
- Advantages & disadvantages to PEDs.
- Conduct of players e.g. etiquette.
- Strategies to combat hooliganism and poor behaviour.



Energy, Diet, Nutrition & Hydration

- Energy factors & guidance
- Factors affecting dehydration
- Healthy balanced diet & nutrition

The Concept of Energy Balance

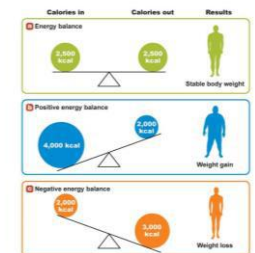

Use of data

Types of data
Analysing & interpreting data



KNOW IT

1. What defines a skill?
2. What makes a skill open or closed?
3. What is meant by the term gross/fine?
4. What are the four stages of the information processing model?
5. What are the four types of guidance?
6. What are the 6 types of feedback a performer can be given?
7. What does the acronym SMART stand for?
8. What are the social factors affecting participation?
9. What are the 7 groups of PEDs athletes may use?
10. What is a sedentary lifestyle?
11. What is a balanced diet made up of?

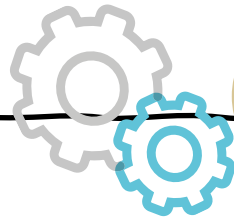

THINK IT

1. Pick a skill and place it on a continuum to cover all factors.
2. Explain each stage of the information processing model.
3. How can a coach use mechanical guidance in swimming?
4. Explain the best type of feedback for a beginner.
5. What factors can be measured in an invasion game?
6. Describe one disability for which sport is adapted.
7. How is blood doping carried out?
8. Explain one negative lifestyle factor.

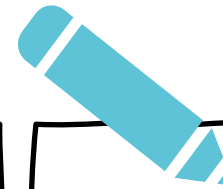

GRASP IT

1. On a continuum describe where a rugby conversion would sit, give reasons for your answer.
2. Using a sport of your choice give an example of what Input might be during a competitive match.
3. Evaluate the use of guidance for an elite performer.
4. Explain the difference between health, fitness & well-being

Year 11

GCSE Physical Education

Paper Two

Physical Education GCSE

Coursework: Part A

Health & Fitness

Health: State of complete mental, physical and social wellbeing and not merely the absence of disease or infirmity

Fitness: Ability to meet the demands of the environment

Components of Fitness

- 1) **Cardiovascular endurance:** the ability of the heart and lungs to supply oxygen to the working muscles.
- 2) **Agility:** The ability to move and change direction quickly (at speed) whilst maintaining control.
- 3) **Balance:** maintaining the centre of mass over the base of support.
- 4) **Co-ordination:** the ability to use different (two or more) parts of the body together smoothly and efficiently.
- 5) **Flexibility:** the range of movement possible at a joint.
- 6) **Muscular endurance:** Ability of a muscle or muscle group to undergo repeated contractions avoiding fatigue.
- 7) **Power / Explosive strength:** the product of strength and speed (strength x speed).
- 8) **Reaction Time:** the time taken to initiate a response to a stimulus.
- 9) **Speed:** the maximum rate at which an individual is able to perform a movement or cover a distance in a period of time (speed = distance divided by time)
- 10) **Strength:** the ability to overcome a resistance
 - a) **Maximal** – the largest force possible in a single maximal contraction
 - b) **Dynamic** – repeated contractions
 - c) **Explosive** – (see POWER)
 - d) **Static** – the ability to hold a body part in a static position

Fitness testing

- Reasons for fitness testing**
- To identify strengths and weaknesses, this allows them to work on weaknesses
 - To allow you to plan your training
 - To show a starting level of fitness
 - To monitor improvement
 - To monitor the success of a training programme
 - To compare against normative data
 - To motivate and set goals

- Limitations of fitness testing**
- Tests are often not sports specific (give an example)
 - They do not replicate the movements in a sport
 - They don't replicate the high pressure environment of sporting activities/non competitive
 - Some are not reliable
 - Some are maximal which means the performer is required to try their best
 - Protocols MUST be followed or else the tests are invalid

Wow words

Attack	Deception	Defence
Dribbling	Assist	Goalkeeping
	Shooting	Passing
	Footwork	Evasion
Formation	Travel	penalty throw
Zonal		

Fitness tests

- **Agility = Illinois agility run:** Cones arranged in 10m x 5 m rectangle with 4 cones down the middle, performer starts face down, performer runs round the cones as fast as possible, performer is timed, compare results to national averages.
- **Cardiovascular endurance = multi-stage fitness test:** Cones set out 20m apart, test gets progressively harder, individual runs 20m in time with 'bleeps', time between bleeps gets shorter as levels increase, performer runs for as long as possible, score recorded as a level when performer finishes e.g. level 8 bleep 4, compare to national averages.
- **Co-ordination = wall toss test:** tennis ball starts in one hand, stand 2m from wall, on 'GO' the performer works for 30 seconds, performer throws ball against wall and catches it with opposite hand, if ball is dropped the time continues, compare to national averages.
- **Muscular endurance = abdominal curl conditioning test:** Performer lies on mat in a sit-up position, partner holds ankles, performer sits up on bleep and down on bleep (staying in time), the test gets progressively harder as bleeps get faster, score is how many sit ups you did, compare to national averages
- **Power / Explosive strength = vertical jump test:** with flat feet, stand and push the wall ruler with fingertips as high as possible, apply chalk to finger tips, from a standing position jump as high as possible marking the ruler with chalk, record height jumped, compare to national averages.
- **Reaction time = ruler drop test:** Place thumb and index finger together of dominant hand, partner holds metre ruler above, without warning partner drops ruler, individual being tested must catch the ruler, measure in 'cm', compare to national averages
- **Maximal Strength test = one rep max:** lift weight once using the correct technique, if completed attempt a heavier weight until heaviest weight is discovered, take 1 rep max weight and divide it by body weight, compare to national averages.
- **Strength = handgrip dynamometer test:** hold dynamometer in dominate hand, bend elbow at 90 degrees and place against body, squeeze with maximum effort, record best score, compare to national averages.
- **Speed = 30m speed test:** set up two cones 30m apart, use a flying start, individual is timed running as fast as they can for 30m, compare to national averages.



KNOW IT

1. What are the demands of your activity?
2. What are your fitness components strengths & weaknesses?
3. Can you give three examples for your strength?
4. Can you give three examples for your weakness?
5. What are your skilled strengths?
6. What are your skills weaknesses?

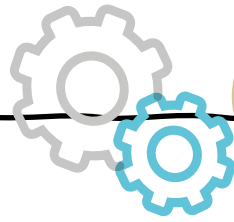

THINK IT

1. What is your justification for these fitness components choices?
2. How are you going to justify your choices?
3. What is the impact on your performances?

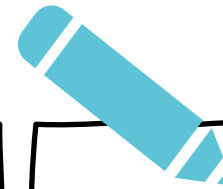
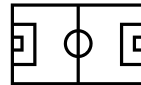

GRASP IT

With reference to a recent competitive performance in the chosen activity, students should identify two strengths and two weaknesses:

Strengths

One strength should be a fitness component
One strength should be a skill/technique

Weaknesses

One weakness should be a fitness component
One weakness should be a skill/technique

Year 11

GCSE Physical Education

Coursework

Religious Studies: Religion and Life

1. Origins of the Universe

The Big Bang Theory says that the universe began 20 billion years ago. There was nothing and then a huge explosion made clouds of dust and gas and over time the universe formed. Scientific evidence supports this theory. Scientists know the universe of expanding, and they can track the expansion back to a singular point - explosions cause everything to be flung outwards. Background microwaves radiation from the explosion can still be detected in space.

4. Key Quotes

'where a person is definitely going to die, and keeping them alive leads to more suffering, then termination of life is permitted under Mahayana Buddhism' Dalai Lama

'God created life in his own image.' (Genesis)

"Do not Kill" (Ten Commandments - Exodus)

'I, your God, give life and I take it away.' (Job)

2. Genesis

Genesis is the first Book of the Hebrew Bible. The Genesis creation story believed by Jews, Muslims and Christians.

In the beginning there was nothing. Then over seven days God created light and dark, the heavens, land, sea and vegetation, sun, moon and stars, birds and fish, land animals and humans. On the seventh day God rested - it was a 'good' creation.

Literal Christians- Some people believe it is **literally true**. God is all-powerful so it is easy to believe that God did all this in literally seven days.

5. Environmental Damage

Pollution: damage and solutions - Pollution causes damage to the sea, (water) and land. Anything can be polluted - there is both light and noise pollution. Factories and transport cause the most air pollution - toxic CO2 in the air damages the ozone layer, thus reducing its ability to keep the earth cooler. Rain picks up the chemicals and drops them in acid rain, polluting land, water and crops and buildings. Factories empty their waste into rivers and farming chemicals drain from the land into the water sources, killing fish and wildlife.

3. WOW Words

- **🔑 ABORTION:** Deliberate termination of a pregnancy, with the intention to prevent life.
- **🔑 AFTERLIFE:** Beliefs about what happens to our self/soul after we die.
- **🔑 ANIMAL EXPERIMENTATION:** Use of animals to test for toxicity and validity of medicines.
- **🔑 AWE AND WONDER:** Sense of amazement.
- **🔑 BIG BANG THEORY:** the scientific view of the beginning of the universe.
- **🔑 DOMINION:** The idea that humans have the right to control all of creation.

6. Science and Religion

Depending on the situation, sometimes one is more important than the other. Sometimes we need hypothesis and testing, they help us make sense of how things work, and repeated testing shows us things work. It is not enough to simply believe that medicines work, they need to be tested. At the same time religious truths give life meaning and purpose, a sense of well-being, as well as hope of something else after life here.



KNOW IT

1. What is a literal Christian ?
2. What is a liberal Christian ?
3. What is the 'Big Bang' theory ?
4. What evidence supports the 'Big Bang' theory ?
5. What does the Bible tell us about how the world began ?
6. What is the theory of Evolution ?
7. What is 'awe and wonder' ?
8. What is the book of Genesis ?
9. Give two ways humans have polluted the planet.
10. Why is religion important in everyday life ?

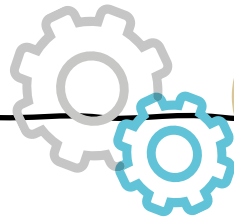

THINK IT

1. Explain how a **liberal Christian** would explain how the 'Big Bang' theory and the story of Genesis are compatible.
2. Explain why protecting the environment is important to Muslims.
3. What do Christians believe about the afterlife ?
4. Why is abortion a controversial issue ?
5. Explain a **Conservative Christian's** viewpoint on Euthanasia.

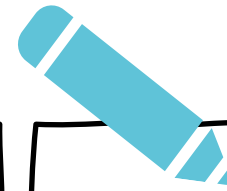

GRASP IT

1. What are your viewpoints on animal testing ? Write a paragraph explaining this.
2. What is sustainable development ? Explain the importance of this concept for future generations.
3. Use an example to explain when a woman's **quality of life** is more important than the **sanctity of life**.
4. What happens when we die ? Explain what you think or believe.

Science: Electricity

3. WOW WORDS

Series circuit – a circuit where all of the components are connected in a single loop

Parallel circuit – a circuit where the components are connected using multiple loops or “branches”

Current – the flow of charge in an electric circuit

Resistance – a measure of how easily current can flow

Mains electricity – the electricity that is supplied to our homes. It has a p.d. of 230V and a frequency of 50Hz

National grid – a network of power cables, pylons and transformers that allow electricity to travel from the power station to homes and businesses

Section 1: Series and Parallel circuits

In a series circuit the current is the same everywhere in the circuit but in parallel circuits the current splits between the branches.

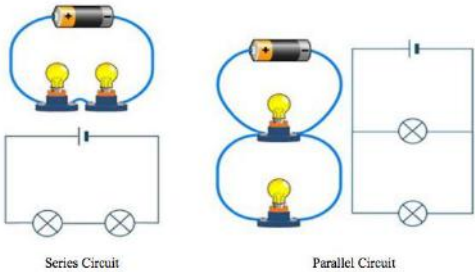

Section 2: Circuit symbols

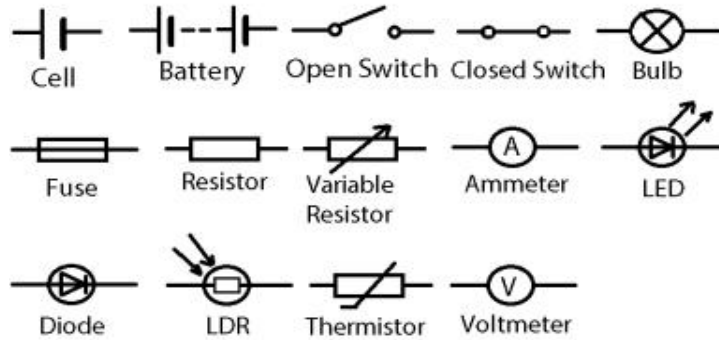

Scientists use circuit symbols so that other scientists can understand their diagrams and recreate their circuits.

Section 6: Separates Static electricity

Charge. It occurs when electrons move from one material to another, usually from rubbing materials together.

If an object gains electrons it becomes negatively charged.

If an object loses electrons it becomes positively charged

If we rub a balloon on our jumper it will charge the balloon enough for it to stick to the wall. Static can be dangerous if enough builds up. Lightning is caused by a build-up of static in the sky.

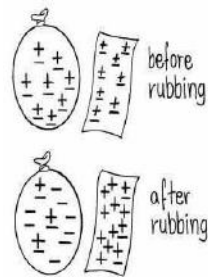

Section 4: Wiring a plug

This diagram shows a plug.

1. Is a plate that holds the wire in place
2. Neutral wire
3. Earth wire
4. Live wire
5. Fuse

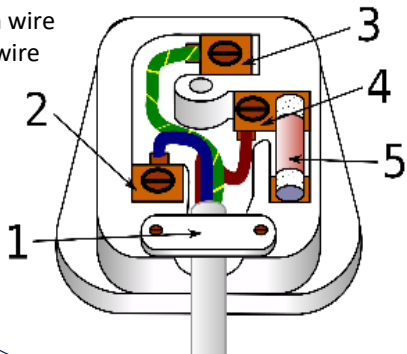

Section 5: The national Grid

Electricity gets to our homes via the national grid. Power cables carry the electricity at a very high voltage so that a low current can be used and less energy is lost as heat.

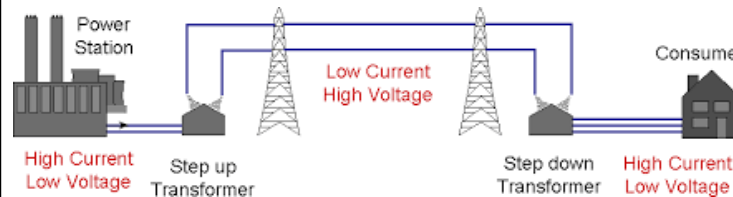

Transformers step up the voltage from the power station and then step it down near our homes.



KNOW IT

1. Describe how the currents in a series circuit and a parallel circuit differ.
2. Draw a fully labelled series circuit that contains a switch, a battery and two lamps. What is an ohmic conductor?
3. What does a.c stand for? Give an example of where a.c is used.
4. What is the frequency and potential difference of mains electricity in the U.K?
5. State the equation that links power, potential difference and current. Include equation symbols and units.
6. State the equation that links power, current and resistance. Include equation symbols and units
7. Calculate the current in a circuit if a charge of 4 C flows in 20 seconds.
8. Describe fully how electricity is transmitted from power stations to our homes.

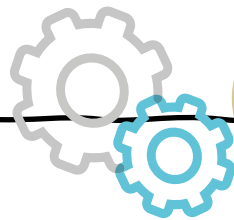

THINK IT

1. State the conditions required for the resistor to obey ohm's law.
2. A teacher wants to demonstrate the properties of series and parallel circuits. The teacher sets up a circuit with three identical filament lamps connected in series with a battery and an open switch. Draw the circuit that the teacher would set up.
3. Explain why adding resistors in parallel decreases the total resistance
4. Explain why the current through the powerline is made as low as possible in The National Grid.
5. Describe how the current is reduced before transmitting the electricity through the powerlines.
6. A plastic rod has been given a positive charge by rubbing the plastic rod on a cloth. Explain how the plastic rod has been given a positive charge in terms of movement of particles.
7. An overhead powerline is used to transmit electricity from power stations to our homes. A powerline carries a current of 350 A and has a power loss of 4 MW. Work out the resistance of the powerline.

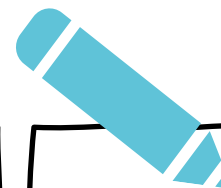

GRASP IT

1. Describe the difference between ohmic and non-ohmic conductors. Sketch current- potential difference graphs for ohmic and non-ohmic conductors.
2. In 2005, a law was passed stating that only qualified electricians could carry out electrical installations in the home. Discuss with your peers the advantages and disadvantages of this law.
3. When insulating materials are rubbed a charge can build up. What determines whether the material builds up a positive or a negative charge?
4. Power stations can be connected to homes using overhead or underground powerlines. Discuss the advantages and disadvantages of both types of powerline.
5. The live wire in a three core electrical cable is brown. The live wire used to be red. Find out why the colour of the live wire has changed.

Science: SPACE

The solar system

Our solar system consists of our star, the Sun, and everything bound to it by gravity — the planets Mercury, Venus, Earth, Mars, Jupiter, Saturn, Uranus and Neptune, dwarf planets such as Pluto, dozens of meteoroids .

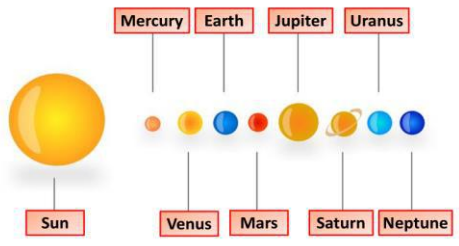

Polar orbits take the satellites over the Earth's poles. The satellites travel very close to the Earth (as low as 200 km above sea level), so they must travel at very high speeds (nearly 8,000 m/s).

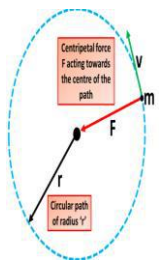

Geostationary satellites take 24 hours to orbit the Earth, so the satellite appears to remain in the same part of the sky when viewed from the ground. These orbits are much higher than polar orbits (typically 36,000 km) so the satellites travel more slowly (around 3 km/s).

- The centripetal force needed to keep an object moving in a circle increases if:
- the mass of the object increases
 - the speed of the object increases
 - the radius of the circle in which it is travelling decreases

Orbits

If the satellite is moving too slowly then the gravitational attraction will be too strong, and the satellite will fall towards the Earth. A stable orbit is one in which the satellite's speed is just right— it will not move off into space or spiral into the Earth, but will travel around a fixed path.

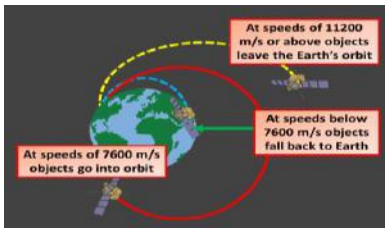

Life Cycle of a star

A nebula: A star forms from massive clouds of dust and gas, known as a nebula, Nebulae are mostly composed of hydrogen.

Protostar: As the mass falls together, it gets hot. A star is formed when it is hot enough for the hydrogen nuclei to fuse together to make helium. The fusion process releases energy, which keeps the core of the star hot.

Main sequence star: This is the stable phase in the life of a star, the force of gravity holding the star together is balanced by higher pressure due to the high temperatures.

Red giant star: When all the hydrogen has been used up in the fusion process, larger nuclei begin to form and the star may expand and becomes red giant.

White dwarf: When all the nuclear reactions are over, a small star may begin to contract under the pull of gravity. In this instance, the star becomes a white dwarf which fades and changes colour as it cools.

Supernova: A larger star with more mass will go on making nuclear reactions, getting hotter and expanding until it explodes as a supernova.

Neutron star or black hole: Depending on the mass at the start of its life, a supernova will leave behind either a neutron star or a black hole.

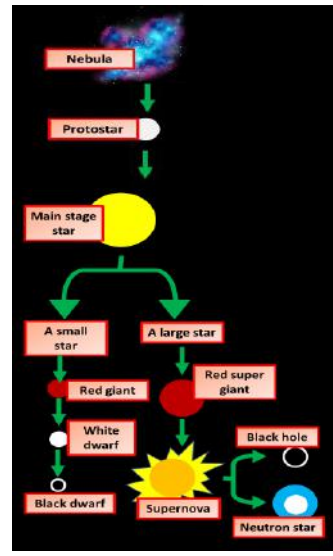

3. WOW WORDS

Life cycle of a star: Stages in the formation of stars

Orbit: The time taken for the sun to orbit the Earth.

Wavelength: The distance between two identical points on a wave.

Asteroids: is a minor planet of the inner Solar System.

Gravity: A force that acts between objects.

Comets: cosmic snowballs of frozen gases, rock, and dust that orbit the Sun.

Satellite: Any celestial body orbiting the Earth.

Geocentric model: A theory that explains the structure of the solar system (or the universe) in which Earth is assumed to be at the centre of it all.

Heliocentric Model: The astronomical model in which the Earth and planets revolve around the Sun at the centre of the universe.

Red Shift

Light from a star does not contain all the wavelengths of the electromagnetic spectrum. Elements in the star absorb some of the emitted wavelengths, so dark lines are present when the spectrum is analyzed. Different elements produce different patterns of dark lines. The diagram shows part of the emission spectrum of light from the Sun

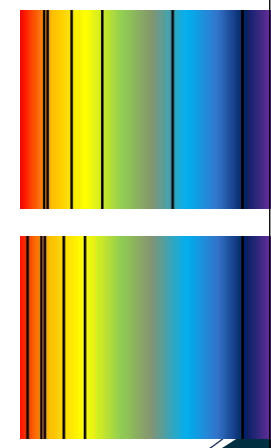



KNOW IT

1. Name the planets in our Solar System in order of distance from the sun.
2. What type of object is Pluto?
3. What is the name of our galaxy?
4. What force pulls the dust and gas together?
5. What is an artificial satellite?
6. Describe what a nebula is?
7. Explain why Pluto is no longer described as a planet?
8. Explain what evidence that Scientist collect when they observe planets?
9. In what direction does the centripetal force act?
10. Describe what is meant by a circular orbit?
11. Explain the relationship between the distance from the sun and the temperature of the planet.

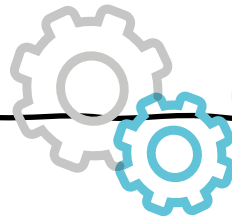

THINK IT

1. Which elements are produced in fusion in stars?
2. Where are elements heavier than this produced?
3. What shape are the orbits of the planets?
4. What is nuclear fusion?
5. Explain how planets are held in place?
6. Explain the process of circular motion?
7. What is the Big Bang theory?
8. Explain the evidence for the Big Bang?
9. Explain the pathway of an orbit of the sun?
10. Describe the relationship between the speed of a galaxy and the distance the galaxy is from the Earth
11. Write down the equation that links distance travelled (s), speed (v) and time (t).
12. The mean distance between the Sun and the Earth is 1.5×10^{11} m. Light travels at a speed of 3.0×10^8 m/s. Calculate the time taken for light from the Sun to reach the Earth.

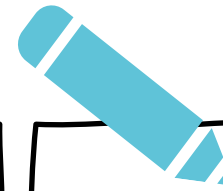

GRASP IT

1. How does nuclear fusion relate to stars?
2. Explain the Doppler Effect?
3. Explain what the red shift is?
4. Some stars are much more massive than the Sun. Describe the life cycle of stars much more massive than the Sun, including the formation of new elements.
5. Explain how the doppler effect is evidence for the big bang?
6. **Figure 1** shows the velocity of the satellite at two different positions in the orbit. Explain why the velocity of the satellite changes as it orbits the Earth.

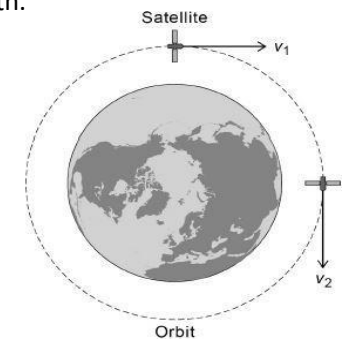



KNOW IT

1. What is crude oil?
2. What is an alkane?
3. What is an alkene?
4. List some uses of alkanes
5. Name the first 4 alkanes
6. Identify the products of complete combustion
7. Identify the products of incomplete combustion
8. Which hydrocarbon is the most flammable?
9. Are larger hydrocarbons more or less viscous?
10. Do smaller alkanes have low or high boiling points?

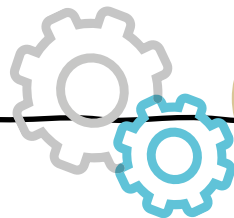

THINK IT

1. Describe how distillation can be used to separate liquids.
2. Explain why larger alkanes don't make good fuels.
3. Write a word equation to show the complete combustion of ethane
4. Write a word equation to show the incomplete combustion of butane
5. Explain what happens during cracking
6. Explain how the properties of hydrocarbons change as they get bigger
7. Explain how crude oil forms
8. Explain how crude oil is separated by fractional distillation
9. Write balanced symbol equations to show both the complete and incomplete combustion of methane (CH_4)
10. Compare alkanes to alkenes

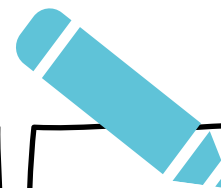

GRASP IT

1. Hydrogen can be used as a fuel. Find out why it isn't commonly used in vehicles.
2. Write a diary detailing everything you do over the weekend. Consider how your weekend would have been different if we couldn't use crude oil
3. Research some common uses of alkenes
4. Research biodiesel and consider its advantages and disadvantages
5. Research electric cars. What are the pros and cons compared to traditional petrol/diesel cars.

Seps Only

1. Explain the structure of a DNA polymer chain?
2. Draw the product formed when ethene reacts with bromine.
3. Draw the structural formula for the first 4 carboxylic acids and name them.
4. Explain how an Ester is made.
5. Compare and contrast the difference between a condensation polymer and naturally occurring polymers

Science: Physics - Forces

1. Scalars and Vectors

Scalar quantities have magnitude (size) only (e.g. length, area, volume, speed, mass, density, temperature, energy, work, power)

Vector quantities have magnitude and an associated direction (e.g. displacement, velocity, acceleration, momentum, forces)

A vector quantity may be represented by an arrow drawn to scale so that its length represents the magnitude of the vector.

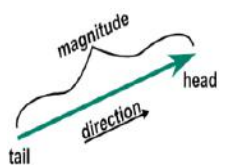

2. Weight

Weight is the force acting on an object due to gravity.

$$\text{weight (N)} = \text{mass(kg)} \times \text{gravitational field strength (N/kg)}$$

The weight of an object may be considered to act at a single point, the object's 'centre of mass'.

The weight of an object and the mass of an object are directly proportional.

Weight is measured using a calibrated spring-balance (a Newton meter).

3. Contact and Non-contact Forces

Contact forces: interactions between objects that touch

Non-contact forces: attract or repel, even from a distance



applied force



spring force



drag force



frictional force

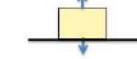

normal force



magnetic force



electric force



gravitational force

5. Elasticity

Hooke's Law tells us that the extension of an elastic object, such as a spring, is directly proportional to the force applied, provided that the limit of proportionality is not exceeded.

$$\text{Force(N)} = \text{spring constant(N/m)} \times \text{extension(m)}$$

A force that stretches (or compresses) a spring does work and elastic potential energy is stored in the spring.

Provided the spring is not in-elastically deformed, the work done on the spring and the elastic potential energy (E_e) stored are equal.

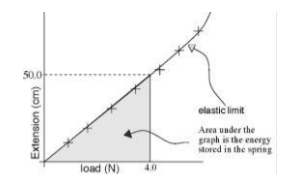

4. Resultant Forces

A number of forces acting on an object may be replaced by a single force that has the same effect as all the original forces acting together. This single force is called the resultant force. A force does work on an object when the force causes a displacement of the object. The work done by a force on an object can be calculated using the equation:

work done (J) = force (N) × distance moved along the line of action of the force (m) One joule of work is done when a force of one newton causes a displacement of one metre (1 joule = 1 newton-metre)

(HT only) A single force can be resolved into two components acting at right angles to each other. The two component forces together have the same effect as the single force.

6. Distance, Displacement and Speed

Distance is how far an object moves. Distance does not involve direction so it is a scalar quantity.

Displacement is the distance from the start point to the end point as the crow flies (as a straight line) so it is a vector quantity.

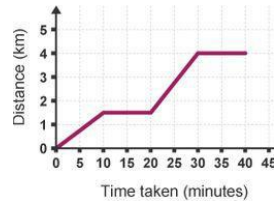
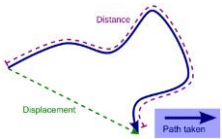

Speed does not involve direction so it is a scalar quantity. The velocity of object is its speed in a given direction so it is a vector quantity.

If an object moves along a straight line, the distance travelled can be represented by a distance–time graph.

The speed of an object can be calculated from the gradient of its distance–time graph.

(HT only) If an object is accelerating (curved line), its speed at any particular time can be determined by drawing a tangent and measuring the gradient of the distance–time graph at that time.

8. Moments Physics (only)

The turning effect of a force is called the moment of the force. If an object is balanced, the total clockwise moment about a pivot equals the total anticlockwise moment about that pivot. **moment of a force (Nm) = force (N) × perpendicular distance from the pivot (m)**

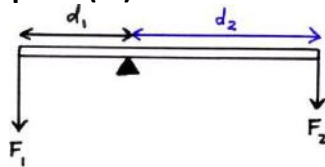

Gears can also work as force multipliers.

7. Acceleration and Momentum

Acceleration (m/s²) = change in velocity (m/s) / time taken (s)

An object that slows down is decelerating.

The acceleration of an object can be calculated from the gradient of a velocity–time graph.

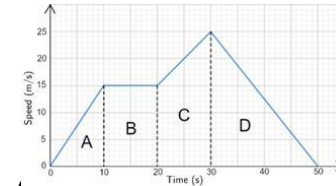

momentum (kg m/s) = mass (kg) × velocity (m/s)

$$p = m v$$

In a closed system, the total momentum before an event is equal to the total momentum after the event. This is called conservation of momentum.

9. Newtons Laws

Newton's First Law

If the resultant force acting on an object is zero:

- a stationary object remains stationary
- a moving the object continues to move at the same velocity

Newton's Second Law

The acceleration of an object is proportional (\propto) to the resultant force

acting on the object, and inversely proportional to the mass of the object. Resultant force (N) = mass (kg) × acceleration (m/s/s)

Newton's Third Law

Whenever two objects interact, the forces they exert on each other are equal and opposite.



KNOW IT

State whether the following quantities are scalars or vectors: Acceleration, Mass, Momentum, Time

Name two forces that act at a distance.

A boy has a mass of 40 kg. Calculate the boy's weight
($g = 10 \text{ N/kg}$).

Name three contact forces.

Calculate the resultant force acting on the object below:

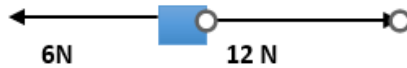

A piano is pushed 3.5m across a wooden floor with a force of 2500 N. Calculate the work done.

A beaker is filled to a depth of 10 cm with water. Water has a density of 1000 kg/m^3 . Calculate the pressure acting at the bottom of the beaker. Take $g = 10 \text{ N/kg}$.

A 30 cm long spanner is used to undo a nut. A force of 20 N is applied to the end of the spanner. Calculate the moment.

Explain how the extension of a spring is determined

Describe the difference between speed and velocity.

TOTAL SCORE:

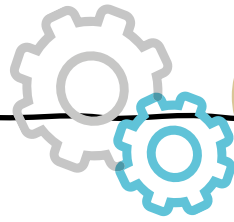

THINK IT

Describe the difference between scalars and vectors

Describe the difference between speed and velocity.

Explain how a car moving around a traffic island at a steady speed of 20 mph is constantly accelerating.

Draw a free body diagram to show the forces acting on a book being pushed along a **horizontal** table.

An astronaut has a weight of 750 N on Earth, where the Gravitational field strength is 9.8 N/kg . Work out the mass of the astronaut.

A crane is used to lift a pallet on a building site. The pallet has a weight of 8500 N and is raised 24 m. Work out the work done against gravity.

A typical mountain bike spring has a spring constant of $90\,000 \text{ N/m}$ and can be compressed 6 cm. Work out the energy stored in the spring when compressed 6 cm.

Two children, **Child A** and **Child B**, sit on either side of a balanced see-saw. **Child A** has a weight of 450 N and sits 1.4 m from the pivot. **Child B** sits 1.6 m from the pivot. Work out the weight of **Child B**.

A motorbike and rider have a combined mass of 320 kg. The driving force supplied by the motorbike's engine is 6700 N. Work out the acceleration of the motorbike and rider.

Give three factors that will increase the thinking distance and three factors that will affect the braking distance of a car.

TOTAL SCORE:

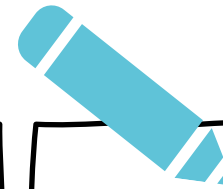

GRASP IT

Jupiter is approximately 11 times the diameter of the Earth. The gravitational field strength of Jupiter is only 2.5 times greater than that of Earth. Why?

When the space shuttle enters the Earth's atmosphere at 17,500 mph its temperature will exceed $1500 \text{ }^\circ\text{C}$. Why?

What is the stretchiest material that has been discovered? Where is it used?

Discuss advantages and disadvantages to everyday situations about being able to switch gravity off

Old mechanical watches had gears to control the rate that the second hand and hour hand rotated. Investigate to see how the gears were made so small, and how they fitted together.

Find out the maximum depth that modern nuclear submarines can sink to. How would this depth change in fresh water compared to sea water.

The stopping distances in the highway code were written in the 1970's. Discuss how the design of cars since the 1970's will have changed the stopping distances from the stated values.

Distractions when driving causes crashes. Discuss the reasons why people still use their mobile phones when driving, when mobile phone use was responsible for 492 crashes in 2014 alone.

Motorcyclists are 35 times more likely to die in a crash compared to car drivers. Motorcycle crash helmets do help prevent injuries. Explain how crash helmets reduce injuries in terms of momentum.

Find out which is more elastic – steel or rubber.

TOTAL SCORE:

Science: Chemical Analysis

TESTING FOR GASES

Test for Carbon dioxide CO₂

Carbon dioxide gas

Limewater (clear/colourless)

Limewater (cloudy/milky)

Test for Hydrogen H₂

Hydrogen makes a squeaky pop with a lighted splint

POP!

Test for Oxygen O₂

Oxygen relights a glowing splint

Glowing splint

Oxygen

Test for Chlorine Cl

Chlorine bleaches damp blue litmus paper

Blue

Red

White

Chlorine gas

PURITY AND FORMULATIONS

A **pure substance** is something that only contains one compound or element throughout – not mixed with anything else

Pure substances

In chemistry, we refer to a substance as being pure if nothing has been added to it. A pure substance is a compound or element that is not mixed with anything else.

Carbon dioxide Oxygen

Impure substances

Impure substances are usually mixtures or have had something added to it.

Alcohol and water Oxygen and Helium

Formulations are useful mixtures with a precise purpose that are made by following a formula. Each component in a formulation is present in measured quantity and contributes to the properties of the formulation so that it meets its required function e.g. formulations are important in the pharmaceutical industry when altering the formulation of a pill/drug

3. WOW WORDS

- ***Formulation** - a mixture that has been designed to be a useful product
- ***Chromatography**– An analytic method to separate a mixture that has different colours.
- ***Chromatogram** – shows the results of a chromatography experiment.
- ***Stationary phase** - A phase in chromatography where the molecules can't move
- ***Mobile phase** - A phase in chromatography where the molecules can move
- ***Solute** – a substance dissolved in a solvent to make a solution
- ***Solvent** – a liquid in which another substance (solute) can be dissolved
- ***Solvent front** – the point the solvent has reached up the filter paper
- ***Rf value** – the ratio between the distance travelled by a dissolved substance and the distance travelled by a solvent

CHROMATOGRAPHY

Chromatography is an analytical method used to separate the substances in a mixture. In paper chromatography, the **stationary phase** is the chromatography paper and the **mobile phase** is the **solvent** (ethanol or water). In an experiment, the mobile phase moves through the stationary phase. How quickly it moves depends on how **soluble** the molecules are in the solvent, and how attracted they are to the paper.

Molecules with higher solubility and which are less attracted to the paper will be carried further up the paper.

CHROMATOGRAPHY REQUIRED PRACTICAL

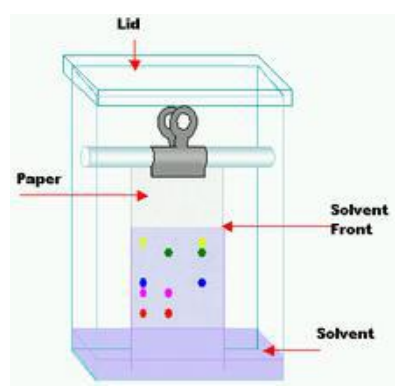

The result of chromatography analysis is called a **chromatogram**.

An **Rf value** is the ratio between the distance travelled by the dissolved substance (solute) and the distance travelled by the solvent.

You calculate Rf values using the formula:

$$R_f = \frac{\text{Distance travelled by substance}}{\text{Distance travelled by solvent}}$$

Rf Values

The further through the stationary phase a substance moves, the larger the Rf value.

Chromatography is often carried out to see if a certain substance is present in a mixture. To do this, you run a pure sample of that substance (a reference) alongside the unknown mixture. If the Rf values of the reference and one of the spots in the mixture match, the substance may be present.

The Rf value of a substance is dependent on the solvent you use - if you change the solvent the Rf value for the substance will change.

TESTS FOR ANIONS

Tests for **anions** often give precipitates.

You can test for carbonate ions by adding a few drops of dilute acid. If carbonate ions are present, this will release carbon dioxide which will turn limewater cloudy.

You can test for sulfate ions by adding a couple of drops of dilute HCl followed by a couple of drops of barium chloride solution. If sulfate ions are present, a white precipitate of barium sulfate will form.

You can test for halide ions by adding a couple of drops of dilute nitric acid followed by a couple of drops of silver nitrate solution.

FLAME TESTS FOR CATIONS

Compounds of some metals produce a characteristic colour when heated in a flame so you can test for various metal ions by heating your substance and seeing whether the flame turns a distinctive colour

Element	Ion	Flame test colour
Lithium	Li ⁺	Crimson
Sodium	Na ⁺	Yellow
Potassium	K ⁺	Lilac
Calcium	Ca ²⁺	Orange-red
Copper	Cu ²⁺	Green

FLAME EMISSION SPECTROSCOPY

During **flame emission spectroscopy** a sample is placed in a flame. As the ions heat up, their electrons become excited (they move to higher energy levels). When the electrons drop back to their original energy levels, they release energy as light.

The light passes through a spectroscope which can detect different wavelengths of light to produce a line spectrum. A line spectrum for an ion could look like this:

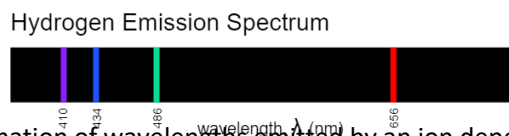

The combination of wavelengths emitted by an ion depends on its charge and its electronic arrangement. Since no two ions have the same charge and the same electron arrangement, different ions emit different wavelengths, and has a different line spectrum. The intensity of the spectrum indicates the concentration of that ion in solution so line spectra can be used to identify ions in a solution and calculate their concentrations.

FLAME EMISSION SPECTROSCOPY

Flame emission spectroscopy can also be used to identify different ions in mixtures. This makes it more useful than flame tests, which only work for substances that contain a single metal ion.

Machines can analyse unknown substances. Chemists often use instrumental analysis (tests that use machines) such as flame emission spectroscopy, instead of conducting manual tests. Advantages of using machines:

- very sensitive
- Very fast and tests can be automated
- Very accurate

3. WOW WORDS

***Diatomic** – molecules that are found in pairs.

***Properties.** Describes how a substance behaves or what it looks like.

***Ion** – a charged particle formed when one of more electrons are lost or gained from an atom or molecule

***Cation** – positive ion.

***Anion** – negative ion.

***Precipitate** – a solid that is formed in a solution during a chemical reaction

***Flame emission spectroscopy** - an analytical technique which can be used to identify and find the concentration of metal ions in a solution

TESTING METALS WITH NAOH

Metal Cation	Effect of adding NaOH
Aluminium (Al ³⁺)	White precipitate, dissolves in excess NaOH to form a colourless solution
Magnesium (Mg ²⁺)	White precipitate, insoluble so remains in excess NaOH
Calcium (Ca ²⁺)	White precipitate, insoluble so remains in excess NaOH
Copper (II) (Cu ²⁺)	Light blue precipitate, insoluble in excess
Iron (II) (Fe ²⁺)	Green precipitate, insoluble in excess
Iron (III) (Fe ³⁺)	Red-brown precipitate, insoluble in excess



KNOW IT

1. Write a definition for a pure substance.
2. Write a definition a definition for an impure substance.
3. Write a definition for a formulation.
4. List 3 examples of a pure substance.
5. List 3 examples of impure substances.
6. List 3 examples of what a formulation is.
7. Identify the gas if lime water turns cloudy.
8. Identify the gas if damp litmus paper turns whit.
9. Give the name of two solvents.
10. Identify the gas if a glowing splint relights?

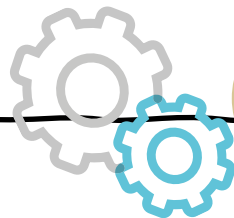

THINK IT

1. Write a method to carry out the required practical for chromatography.
2. Describe a method for testing for hydrogen.
3. Describe a method for testing for oxygen.
4. Describe a method for testing carbon dioxide.
5. What is the difference between the mobile phase and the stationary phase during chromatography.
6. What effect will impurities have on the melting point of a substance.
7. What conditions affect how long molecules are in the mobile phase.
8. If you were testing the same substance with different solvents, what would happen?
9. Calculate the r_f value when the spot sample travelled 3.5 and the solvent line travelled 8.3.
10. Compare the difference in gradients for a pure and impure substance.

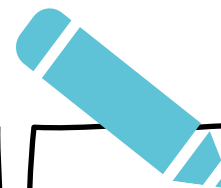

GRASP IT

1. Describe how you would can determine if a substance is pure.
2. How can you tell if a substance was impure by analysing a chromatogram.
3. Calculate the distance travelled by a substance if it has a r_f value of 1.6 and the solvent travelled 8.3 cm .
4. thermal decomposition of calcium carbonate forms CO_2 and calcium oxide. Describe how you could test that this reaction is occurring.
5. During electrolysis, chlorine gas and oxygen gas is formed at the electrodes. How could you test this?
6. **Chem Only:** What colour flames are produced when compounds containing metal ions, copper, potassium and sodium are held in a Bunsen burner.
7. **Chem Only:** Describe a test to determine if it is iron (II) chloride?
8. **Chem Only:** Explain the advantages between flame tests and flame emission spectroscopy
9. **Chem Only:** Draw a flow chart to carry out a flame test.
10. **Chem Only:** In the test for halide ions, why is nitric acid added before silver nitrate is added.

Science: Ecology

Section 1: Biotic and Abiotic Factors

Biotic	Abiotic
Availability of food	Light intensity
New predators arriving	Temperature
New pathogens	Moisture levels
One species outcompeting another	Oxygen levels for aquatic animals
	Wind intensity and direction
	Carbon dioxide levels for plants
	Soil pH and mineral content

Section 4: Carbon Cycle

Photosynthesis	Plants absorb CO ₂ from atmosphere.
Respiration	Animals, plants and micro-organisms respire, releasing CO ₂ into the atmosphere.
Decay	The carbon in dead organisms is released to the atmosphere by micro-organisms respiring.
Combustion	Carbon locked in fossil fuels is released as CO ₂ when fuels are burned.

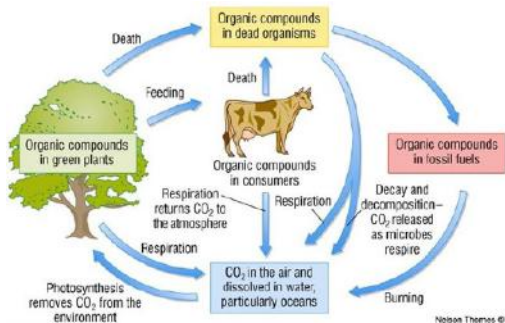

Section 2: Food Chains and Predator-Prey Relationships

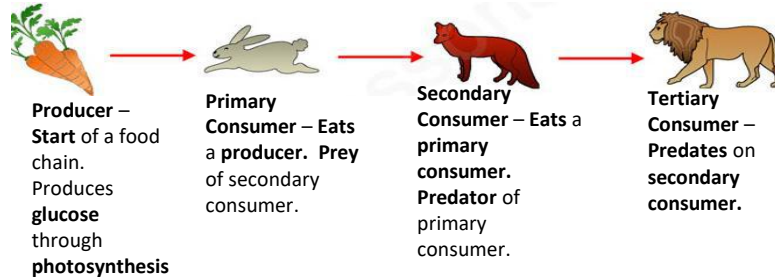

Predator-prey cycles

The population of the **prey** increases
More food is available for the **predators**, so their population increases.
 There are **more predators** so the **population of the prey decreases**.
 There is **less prey to feed on** so the population of **predators decreases**.
 The **cycle restarts** from the beginning.

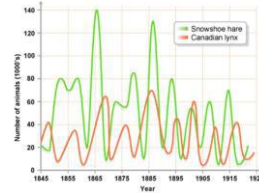

Section 3: Adaptations

Structural Adaptations	Part of the body that helps the organism survive. e.g. polar bears have a thick layer of fat for insulation.
Functional Adaptations	How the body operates that helps the organism survive. E.g. camels do not sweat.
Behavioural Adaptations	A behaviour that helps the organism survive. e.g. desert rats stay in their burrows during the hottest parts of the day.

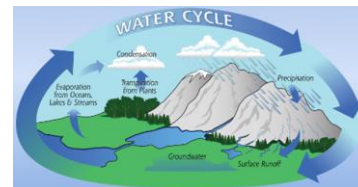

WOW WORDS

Ecosystem	The interaction of a community of living organisms (biotic) with the non-living (abiotic) parts of their environment.
Habitat	The area in which an organism lives .
Community	Two or more different species in an ecosystem. A stable community is one where all the species and environmental factors are in balance so that population sizes remain fairly constant .
Population	The total number of organisms of one species in an ecosystem.
Competition	Plants often compete for light, space, water and mineral ions . Animals often compete for food, mates and territory .
Interdependence	Within a community each species depends on other species for food, shelter, pollination etc.
Adaptations	A feature that an organism has that allows it to survive in its ecosystem.
Biodiversity	The variety of all the different species of organisms on Earth, or within an ecosystem .

Section 5: Water Cycle

Evaporation	Liquid water is turned into water vapour in the atmosphere .
Condensation	Water vapour condenses to form clouds .
Precipitation	Water is deposited from clouds as rain .

Science: Ecology

Section 6: Human Effects on Biodiversity

Human activity	Why it happens	Effects
Polluting water with fertiliser and sewage	Farmers spread fertiliser on fields. Rain washes fertiliser into rivers and ponds. Sewage is released directly into rivers.	Fertilisers and sewage cause an increase in growth of algae . When the algae die , they are decomposed by bacteria that use oxygen . Other animals die due to a lack of oxygen .
Using land	Humans construct buildings , create quarries and farm .	Habitat for plants and animals is reduced .
Destroying peat bogs	Humans use peat to provide compost to increase food production.	Removes habitat, reducing biodiversity . Decay or burning of peat produces CO₂ .
Deforestation	To provide land for cattle and rice fields . To grow crops for biofuels .	Burning or decomposing trees releases CO₂ . Fewer trees to remove CO₂ from the atmosphere . Loss of biodiversity .
Producing acidic gases	Combustion of fossil fuels releases carbon dioxide, sulfur dioxide and nitrogen oxides . These gases dissolve in water making it acidic .	Acid rain . Damages plants . Can cause rivers and lakes to become acidic, killing animals and plants.
Polluting water with toxic chemicals	Pesticides and other toxic chemicals (e.g. from landfill) are washed into rivers and lakes by rain .	Toxic chemicals accumulate in animals. The further up the food chain, the greater the accumulation . Top predators die or fail to breed.
Increasing temperature of the planet (global warming)	Humans release extra greenhouse gases (CO₂ and methane) into the atmosphere and less CO₂ is absorbed by plants through photosynthesis. Greenhouse gases absorb heat and stop it escaping to space.	Loss of habitat as sea levels rise ; animals and plants can no longer survive in certain areas; reduced biodiversity ; change in migration patterns of animals.

Section 7: Maintaining Biodiversity

Breeding programmes for endangered species.
Protection and regeneration of rare habitats.
Reintroduction of field margins and hedgerows in agricultural areas where farmers grow only one type of crop
Reduction of deforestation
Reduction of carbon dioxide emissions by some governments
Recycling resources rather than dumping waste in landfill.

Section 8: Measuring Biodiversity

	Random Sampling	Systematic Sampling (transect)
Purpose	Estimate the size of a population in an area.	See how populations and communities change over a distance.
Method	<ol style="list-style-type: none"> Choose a suitable number of quadrats to use. Assign co-ordinates to the area that you are sampling. Randomly choose co-ordinates. Place the quadrats and count organisms present. Calculate the mean number of organisms. 	<ol style="list-style-type: none"> Use a tape measure to create a long line (transect). Put quadrats at set distances. Count organisms present. Repeat in a different place/ different time of year. Draw graphs to see how communities change over a distance.

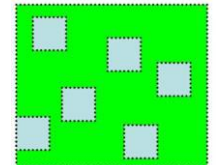



KNOW IT

1. What is the difference between an abiotic and biotic factor?
2. What are the 3 different types of adaptation?
3. Write down the different names for consumers that can be found in a food chain
4. What is the purpose of a quadrat?
5. What processes are involved in the water cycle?
6. What processes are involved in the carbon cycle?
7. What is decay?
8. What is biodiversity?
9. What is meant by the term global warming and what factors lead to it?
10. What is deforestation and why do we do it?

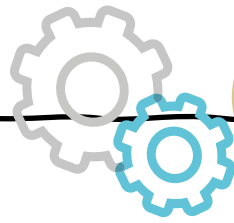

THINK IT

1. Write down 3 abiotic factors and 3 biotic factors
2. What is the difference between the 3 different types of adaptation?
3. What do food chains always start with and where do they get their energy
4. Describe the method for using a quadrat
5. Describe the processes involved in the water cycle
6. Describe the processes involved in the carbon cycle
7. Describe the factors that affect the rate of decay
8. Why is high diversity important?
9. Explain how global warming happens
10. How does deforestation contribute to global warming?

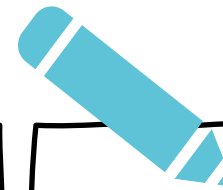

GRASP IT

1. What abiotic and biotic factors affect plant growth?
2. Explain how polar bears are adapted to their environment
3. Draw a food chain for organisms you would find in a woodland or forest
4. Explain how you would calculate the number of daisies in a field using a quadrat
5. Explain how the water cycle ensures water is constantly recycled on Earth
6. Explain how the carbon cycle ensures carbon is constantly recycled on Earth
7. Outline the method used for investigating the rate of decay (lipase, milk, phenolphthalein)
8. How does an increasing population affect biodiversity?
9. Explain the consequences of global warming
10. Describe how we can maintain ecosystems and biodiversity

Science: Inheritance, Variation and Evolution

REPRODUCTION

Sexual reproduction involves the joining (fusion) of male and female gametes; sperm and eggs in animals and pollen and ovule cells in flowering plants. This mixing of genetic information leads to **variation** in the offspring.

Asexual reproduction involves only one parent and no fusion of gametes. There is no mixing of genetic information. This leads to genetically identical offspring (clones). Only **mitosis** is involved.

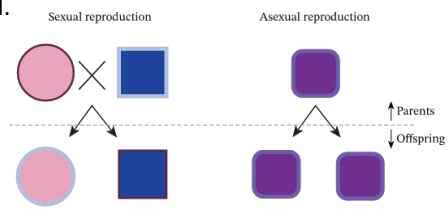

MITOSIS AND MEIOSIS

Gametes are produced by **meiosis**. When a cell divides to form gametes, copies of the genetic information are made and the cell divides twice to form four gametes, each with a single set of chromosomes.

All gametes are genetically different from each other. Gametes join at fertilisation to restore the normal number of chromosomes. The new cell divides by **mitosis**, and as the embryo develops, cells differentiate.

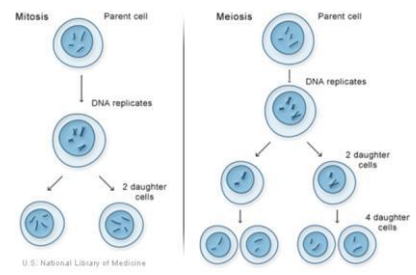

3. WOW WORDS

- ***Gamete** – sex cell e.g. sperm, egg
 - ***Allele** – different form of a gene.
 - ***Genotype** – alleles present e.g. Tt
 - ***Phenotype** – the physical appearance of a characteristic e.g. blue eyes
 - ***Dominant allele** e.g. T- is expressed if only present on one chromosome.
 - ***Recessive allele** e.g. t- is only expressed if present on both chromosomes e.g. tt
 - ***Homozygous** – 2 of the same alleles e.g. TT
 - ***Heterozygous** - 2 different alleles e.g. Tt ***TT** = homozygous dominant
 - ***tt** = homozygous recessive
 - ***Tt** = heterozygous
- Some disorders are inherited, e.g. polydactyly and cystic fibrosis

DNA

DNA is a polymer made up of two strands forming a double helix.
DNA is found in chromosomes.
A gene is a small section of DNA which codes for making a protein.
Each gene codes for a sequence of amino acids to form a particular protein.
The **genome** is all the genetic material of an organism.

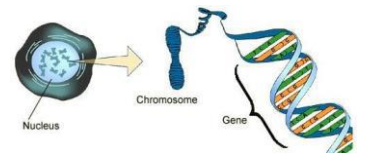

GENETIC DIAGRAMS AND PUNNET SQUARES

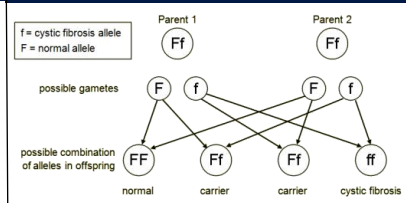

The **allele** which causes cystic fibrosis is a recessive allele, **f**, carried by about 1 person in 25

Genetic diagrams show the possible alleles of offspring; they tell you the probabilities not what will definitely happen.

Gender determination		mother	
		X	X
father	X	XX	XX
	Y	XY	XY

SELECTIVE BREEDING

Differences in the characteristics of individuals may be due to:

- genes they have inherited
- environmental causes
- a combination of genetic and environmental causes.

Selective breeding (artificial selection) is the process by which humans breed plants and animals for useful characteristics. Selective breeding of food plants has produced disease or weather resistant crops and more attractive or better flavoured fruits and crops that are easier to harvest. Selective breeding of animals has produced cows that produce more milk and animals that produce more and/or better flavoured or leaner meat.

One of the problems with selective breeding is that it can lead to 'inbreeding' where some breeds are particularly prone to disease or inherited defects. Some breeds of dogs suffer from inbred defects.

GENETIC ENGINEERING

Genetic engineering involves changing the genome of an organism to introduce a desired characteristic

Genes can be cut from the chromosome of a human or other organism and transferred into the cells of other organisms.

Enzymes are used to cut the gene from a chromosome, the gene is then inserted into a vector (e.g. a bacterial plasmid) which is then used to insert the gene into the cell; the cell then makes a new protein to produce the desired characteristic.

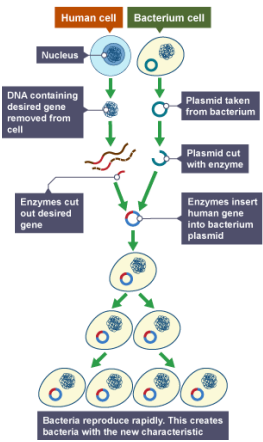

ANTIBIOTIC RESISTANCE BACTERIA

Bacteria can develop random **mutations**, which can lead to changes in the bacteria's characteristics e.g. being less affected by a particular antibiotic. This can lead to antibiotic-resistant strains. Bacteria rapidly reproduce so they can evolve quite quickly.

The problem of antibiotic resistance is getting worse partly because of the overuse and inappropriate use of antibiotics for non-serious conditions or viral infections. Antibiotics create a situation where naturally resistant bacteria have an advantage so increase in numbers. MRSA is a relatively common 'superbug'.

DARWIN'S THEORY OF EVOLUTION

NATURAL SELECTION

- individual organisms within a particular species may show a wide range of phenotype variation because of differences in their genes
- individuals with characteristics most suited to the environment are more likely to survive to breed successfully - **'survival of the fittest'**
- the genes that have enabled these individuals to survive are then passed on to the next generation.
- organisms that are less well adapted are less likely to survive and reproduce
- Over time beneficial characteristics become more common in the population and the species changes – it evolves

Extinction is when no individuals of a species remain. It may be caused by: environment changes too quickly; new predators; new diseases; new, more successful competitors; a single catastrophic event, e.g. volcanic eruptions or collisions with asteroids.

CLASSIFICATION

Classification is organising living organisms into groups. In the Linnaean system, living things are first divided into kingdoms. The kingdoms are then subdivided into smaller and smaller groups.

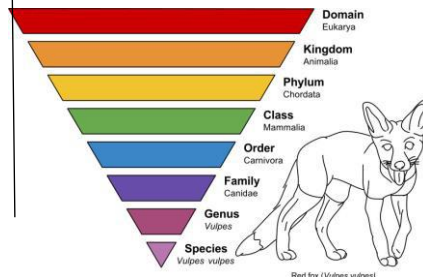

In the three domain system, organisms are first of all split into three large groups called domains:

1. Archaea
2. Bacteria
3. Eukaryota

3. WOW WORDS

- *Enzymes** – a protein that acts as a biological catalyst
- *Gene** - a short section of DNA, found on a chromosome, which contains the instructions needed to make a protein
- *Species** – a group of similar organisms that can reproduce to give fertile offspring
- *Variation** – the differences that organisms of the same species have
- *Mutations** – a rare, random change in an organism's DNA that can be inherited
- *Speciation** – the development of a new species over a long period of time
- *Theory of evolution** – all of today's species have evolved from simple life forms that first started to develop over three billion years ago
- *Classification** – organising living organisms into groups

FOSSILS

Fossils - are the 'remains' of organisms from many years ago, which are found in rocks. Fossils may be formed:

1. GRADUAL REPLACEMENT OF MINERALS - things like teeth, shells, bones don't decay easily and can last a long time when buried. They're eventually replaced by minerals as they decay
2. FROM CASTS AND IMPRESSIONS – fossils form when an organism is buried in a soft material like clay. The clay later hardens around it and the organism decays leaving a cast of itself
3. FROM PRESERVATION IN PLACES WHERE NO DECAY HAPPENS – this can be due to lack of oxygen or moisture which the decay microbes need to survive.



KNOW IT

1. Where in a cell is DNA found?

2. Name the male and female gametes in humans

3. What is mitosis?

4. Draw a Punnett square showing sex inheritance

5. Define the term alleles

6. What is variation?

7. What is the theory of evolution?

8. What is extinction?

9. What is selective breeding?

10. What is genetic engineering?

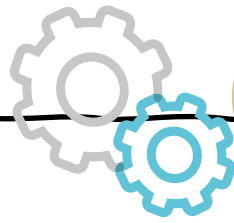

THINK IT

1. What are chromosomes made up of?

2. Describe the difference between sexual and asexual reproduction

3. Describe the process of meiosis

4. Draw a genetic diagram showing sex inheritance

5. What is a dominant and recessive allele?

6. What is the difference between genetic and environmental variation?

7. Describe Darwin's theory of evolution by natural selection

8. Describe the reasons why species become extinct

9. Describe the process of selective breeding

10. Describe how genetic engineering works

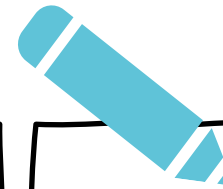

GRASP IT

1. Explain what is meant by the term genome

2. Discuss the advantages of sexual and asexual reproduction

3. Explain how mitosis differs to meiosis?

4. Draw a Punnett square showing what would happen with two heterozygous parents

5. Use examples to describe what is meant by the term genotype and phenotype

6. Explain how a genetic variant is produced

7. Explain why Darwin's theory was initially controversial and then accepted

8. Explain how speciation happens

9. Explain one problem associated with selective breeding

10. Discuss the issues surrounding genetic engineering

Science: Sustainability

<u>Use of resources</u>	<u>Treating water</u>	<u>Key terms</u>
<p>What do we use the earth's resources for?</p> <ul style="list-style-type: none"> • Warmth • Shelter • Food • Transport <p>We recycle and reuse to:</p> <p>Reduce...waste and environmental impacts</p> <p>Reduce...use of limited resources</p> <p>Reduce...use of energy resources</p>	<p>Potable water must have low levels of SALTS and MICROBES (it isn't PURE water)</p> <p>Obtaining potable water in countries with plentiful fresh water e.g. the UK</p> <ul style="list-style-type: none"> • Find a suitable source of fresh water (e.g. lakes, reservoirs, rivers or groundwater aquifers). • Filtration: Pass through filter beds to remove large particles (leaves, twigs etc). • Sterilise to kill microbes (bacteria) e.g. by using chlorine, ozone or ultraviolet light. <p>Obtaining potable water in countries with limited fresh water In dry countries e.g. Spain there's not enough surface or ground water, so seawater must be treated by desalination.</p> <p>Two processes can be used, distillation or reverse osmosis. Both processes need lots of energy so are very expensive.</p> <p>Sewage treatment requires more processes than desalination but uses less energy so could be used as an alternative in areas with little fresh water.</p> <p>Screening Removes rags, paper, plastics and grit that may block pipes.</p> <p>Sedimentation. Allowed to stand in a sedimentation tank so that suspended particles settle out of the water and fall to the bottom of a sedimentation tank to form the sewage sludge. Lighter effluent floats on top.</p> <p>Aerobic digestion of effluent. Effluent separated and air pumped through encouraging aerobic bacteria to break down any organic matter including other microbes.</p> <p>Anaerobic digestion of sewage sludge Bacteria digest the sludge in the absence of oxygen. This breaks it down. Methane and carbon dioxide are produced by the bacteria.</p> <p>Sterilisation If the river is a sensitive ecosystem, then the water is filtered one more time and sterilised by UV light or by chlorine</p>	<p>Finite resource A non-renewable resource used by humans that has a limited supply e.g. coal.</p> <p>Renewable resources A resource used by humans that can be replenished e.g. trees. If not managed correctly, the resource may decrease.</p> <p>Potable water Water that is safe to drink. Has low levels of dissolved salts and microbes.</p> <p>Fresh water Water that has low levels of dissolved salts. Rain water is an example of fresh water but sea water is not.</p> <p>Pure water Only contains water molecules, nothing else.</p> <p>Desalination A process that removes salt from sea water to create potable water. Expensive as it requires a lot of energy.</p> <p>Sewage Waste water produced by people. Contains potentially dangerous chemicals and large numbers of bacteria.</p> <p>Reverse osmosis Uses membranes to separate dissolved salts from salty water.</p> <p>Natural resources have formed without human input, includes anything that comes from the earth, sea or air (e.g. cotton).</p> <p>Synthetic resources are man made</p>
<p><u>Alternative methods of metal extraction</u></p>		
<p>These are used to extract metals from low grade ores</p> <p>Phytomining</p> <p>Plants are grown in soils rich in metals.</p> <ol style="list-style-type: none"> 2. Plants take in copper. 3. BURN plants 4. Metal is then extracted from the ASH <p>Bioleaching</p> <p>Bacteria feed on metal ore</p> <p>'Leachate solution' contains copper compounds.</p> <p>Copper is extracted from the solution using: displacement by scrap iron or electrolysis</p>		

Science: Sustainability

Corrosion Chem only

Corrosion is a chemical reaction which takes place all around us.

The rusting of iron is a type of corrosion. Rusting is a chemical reaction that requires water and oxygen from the atmosphere. This reaction produces iron oxide.

Corrosion prevention:

- Grease
- Painting
- Electroplating
- Sacrificial protection

Ceramics, Polymers and Composites chem only

Ceramic objects are made from soft wet clay which is shaped and then heated in a kiln to harden them. Common ceramics include: bricks, plates, bowls and sculptures

Polymers are made up from repeating units called monomers. Some polymers occur naturally e.g. starch. Some polymers and artificial e.g. plastics
Glass is a composite material. It is produced by mixing sand, limestone (calcium carbonate) and sodium carbonate.

This glass is often called soda lime glass. Borosilicate is a more specialised form of glass. It still contains sand but this time boron trioxide is added.

The Haber Process chem only

The Haber process is used to manufacture ammonia.
The process involves nitrogen gas and hydrogen gas which are combined together to produce ammonia.

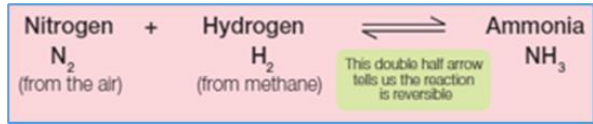

The two reactions balance to form an equilibrium.

The Haber Process is carried out at:

- A temperature of 450 degrees
- A pressure of 200 atmospheres.

These are not the ideal conditions but they are a compromise that reduces the cost and provides a good rate of reaction.

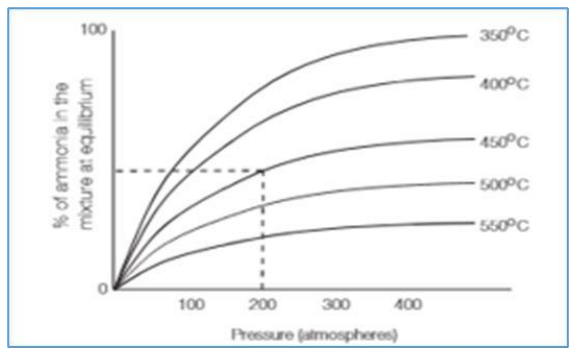

Key terms

- Phytomining** - using plants to extract metals
- Bioleaching** - using bacteria to extract metals
- Leachate** - solution containing metal ions
- Life cycle assessment** – assess the environmental impact of products
- Ceramics** – products made from clay
- Composites** – materials made from 2 or more others
- Polymers** – long chain molecules
- Haber process** – used to make ammonia industrially

Life Cycle Assessments

LCA's are carried out in order to find the impact of a product on the environment.





KNOW IT

1. What three areas do humans process finite resources from?
2. What is meant by the term sustainable development?
3. Why is potable water not described as pure water by scientists?
4. What is used to sterilise water?
5. How is most potable water in the UK produced?
6. What type of ores can phytomining and bioleaching be used on?
7. Why are phytomining and bioleaching used?
8. Life cycle assessments are carried out to assess the environmental impact of what stages of a product?
9. Name three things that reduce the use of limited resources.
10. Name three materials produced from limited resources.

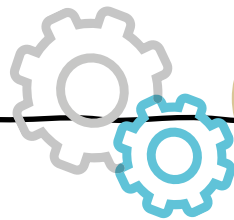

THINK IT

1. Give an example of sustainable development
2. Explain why water is sterilised?
3. Many councils give bins to promote recycling give 3 reasons that they do this
4. Describe the difference between reusing and recycling
5. What are the differences between thermosetting and thermosoftening polymers (chem only)
6. Name four methods of preventing corrosion and how they work (chem only)
7. Why do we use composite materials? (chem only)
8. Describe how clay ceramics made? (chem only)
9. How is potable water produced in the UK?
10. What areas of life cycle assessments can be easily quantified?

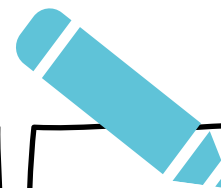

GRASP IT

1. Describe the similarities and differences between the processing of sewage, agricultural and industrial waste water.
2. Explain what is happening when a system reaches dynamic equilibrium (chem only)
3. How is ammonium sulfate produced in the production of fertilisers? (chem only)
4. Complete a life cycle assessment comparing a paper bag to a plastic bag
5. What is the balanced equation for the production of ammonia? (chem only)
6. What compromise conditions are used in the production of ammonia? (chem only)
7. What are the ethical and moral issues behind adding fluorine to drinking water?
8. Bioleaching uses bacteria to make leachate solutions that contain metal compounds, describe two ways the metals are extracted from these solutions
9. Glass bottles can be reused, whereas metal is recycled describe the similarities and differences in these two processes
10. What three areas do humans process finite resources from?

Spanish: Global and Social Dimension

1. LOCAL ISSUES		2. GLOBAL PROBLEMS		3. STAR WORDS	
<p>Problemas de salud</p> <p>Drogas blandas / duras</p> <p>Es un vicio muy caro / peligroso</p> <p>Causa el fracaso escolar</p> <p>Te hace sentir más adulto</p> <p>Es ilegal y peligroso</p> <p>Es fácil engancharse</p> <p>Afecta tu capacidad para...</p>	<p>Health problems</p> <p>Soft / hard drugs</p> <p>it's an expensive / dangerous vice</p> <p>It causes school failure</p> <p>It makes you feel like an adult</p> <p>It's illegal and dangerous</p> <p>It's easy to get hooked</p> <p>It affects your ability to...</p>	<p>Problemas medioambientales</p> <p>La destrucción de los bosques</p> <p>El aire está contaminado</p> <p>Hay demasiada basura en</p> <p>La polución de los mares</p> <p>Los combustibles fósiles se acaban</p> <p>Hay demasiada gente sin...</p> <p>Desastres naturales</p> <p>Un temblor</p> <p>Un incendio forestal</p> <p>Un huracán</p> <p>Un tornado</p> <p>Una tormenta de nieve</p> <p>Unas inundaciones</p>	<p>Environmental problems</p> <p>Destruction of forests</p> <p>The air is polluted</p> <p>There is too much rubbish in...</p> <p>Sea pollution</p> <p>Fossil fuels are running out</p> <p>There are too many people without</p> <p>Natural disasters</p> <p>An earthquake</p> <p>A forest fire</p> <p>A hurricane</p> <p>A tornado</p> <p>A snow storm</p> <p>Flooding</p>	<p>Siempre</p> <p>A veces</p> <p>A menudo</p> <p>Cada</p> <p>Después</p> <p>Antes</p> <p>Cuando</p> <p>Primero</p> <p>Luego</p> <p>Más</p> <p>Sobre todo</p> <p>Juntos</p> <p>Tan/tanto</p> <p>Hasta</p> <p>Ya</p>	<p>Always</p> <p>Sometimes</p> <p>Often</p> <p>Each</p> <p>After</p> <p>Before</p> <p>When</p> <p>First</p> <p>Then</p> <p>More</p> <p>Especially</p> <p>Together</p> <p>So (much)</p> <p>Until</p> <p>Already</p>
4. PALMO		5. SOPHISTICATED OPINIONS – could/ should do		6. KEY VERBS	
<p>How to describe a photo</p> <p>People</p> <p>Action</p> <p>Location</p> <p>Mood</p> <p>Opinion</p> <p>En la foto hay ... personas</p> <p>Está(n)+ gerund (jugando/comiendo)</p> <p>Está (n) en + place</p> <p>Me parece(n) alegre(s) / triste(s)</p> <p>Creo que</p>	<p>Lo que más me preocupa</p> <p>Me preocupa(n)</p> <p>A mi me parecer</p> <p>El mayor problema es</p> <p>Lo más preocupante es</p> <p>Se puede + infinitive</p> <p>Se debería + infinitive</p> <p>Se debe + infinitive</p> <p>Hay que + infinitive</p> <p>Si tuviera el tiempo/el dinero /la oportunidad + conditional</p>	<p>The thing that most worries me</p> <p>... worries me</p> <p>It seems to me</p> <p>The worst problem is</p> <p>The most worrying thing is</p> <p>You can</p> <p>You should</p> <p>You must</p> <p>You must</p> <p>If I had the time / money / opportunity I would...</p>	<p>Desenchufe</p> <p>Apago la luz</p> <p>Me ducho</p> <p>Me baño</p> <p>Separo la basura</p> <p>Reciclo papel / vidrio</p> <p>Malgasto agua</p> <p>Uso / utilizo</p> <p>Daña (los pulmones)</p> <p>Bebo alcohol</p> <p>Tomo drogas</p> <p>Fumo</p> <p>Inculca los valores</p> <p>Eleve el orgullo</p>	<p>I unplug</p> <p>I switch off the light</p> <p>I shower</p> <p>I have a bath</p> <p>I separate rubbish</p> <p>I recycle paper/glass</p> <p>I waste water</p> <p>I use</p> <p>It damages (your lungs)</p> <p>I drink alcohol</p> <p>I take drugs</p> <p>I smoke</p> <p>It instills values</p> <p>It elevates pride</p>	



KNOW IT

1. Translate: The most important thing to me is my family.
2. Translate: I recycle.
3. Translate: the thing that worries me the most is the environment.
4. Translate: it's important that you recycle
5. Translate: I don't waste water
6. Translate: You must shower instead of having a bath (use au lieu de)
7. Translate: you should help developing countries
8. Translate: You can do charity work.
9. Write a sentence explaining what is important to you in life.
10. Write down two things that worry you.

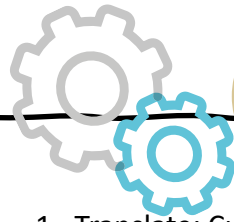

THINK IT

1. Translate: Currently I do quite a lot to protect the environment.
2. Translate: If I had the time I could separate the rubbish.
3. Translate: Everyone should go to school by bike.
4. Translate: You must use public transport.
5. Write a sentence explaining what you could / should do to help the environment.
6. Translate: Volunteering makes me feel more confident.
7. Translate: It's important to participate in society.
8. Change question 1 and 2 into the third person singular (he / she)
9. Translate: An advantage of this event is that it increases national pride.
10. Give a disadvantage of the Olympics.

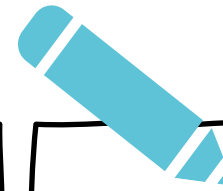

GRASP IT

1. Create three sentences in the conditional about what you could do to protect the environment more. Use a different sentence starter each time.
2. Give two reasons as to why volunteering is important.
3. Give an advantage and a disadvantage of a world event.
4. How many ways do you know to introduce an argument?
5. Give three ways of introducing the other side of the argument.
6. Write down 10 key verbs linked to this topic.
7. Create 2 negative sentences to say what you don't currently do to help the environment using ne jamais/ nepas
8. Prepare a 30 second presentation to highlight the pros and cons of a world event of your choice.
9. Décris la photo. Use PALMO

Design & Technology Core Technical Principles

1. New and Emerging Technologies

Automation: Automated machines are programmed to carry out a procedure multiple times, e.g. repeatedly creating the shape of a car door using a press, to improve production time.

Robotics: Robots are one part of automation but robots use AI to collect information and improve the performance of a procedure.

4. Energy Generation and Storage

Fossil fuels are a finite resource, meaning that they cannot be replaced once extracted from the ground. Examples of fossil fuels are coal, oil and natural gas.

Nuclear Power: A huge amount of energy can be produced through the nuclear process using a relatively small amount of **uranium**. The energy is produced as heat through the **fission process**. It is more efficient than fossil fuels and no harmful gasses are released however disposal of uranium is difficult and costly.

Renewable energy: Solar – uses **sunlight** to generate energy, huge source of free source to create power, the panels can be **expensive** and will produce **less energy** in **winter**. **Wind** – uses the wind to generate energy through wind turbines, **does not pollute** the air, has **expensive** set-up costs, some people do not like their **appearance**.

Batteries: The two main types of batteries that are commonly used are 'single-use' and 'rechargeable'. Alternatively a **wind-up mechanism** allows the user to generate energy by using muscle power to turn a hand crank. This provides **kinetic energy** to power the device, requires no additional batteries and is ready to be used whenever the user needs it.

2. Developments in New Materials

A **modern material** is a material that has been developed through the invention of new or improved processes to improve the **properties** of the **material**, e.g. to make them **stronger, faster, lighter** and **tougher**. Examples are **graphene, LCD's** and **nanomaterials**.

Smart Materials: exhibit a **physical change** in response to some **external stimuli**.

Shape-memory alloys are metal **alloys** that can remember their shape when heated, e.g. Nitinol used in dental braces and glasses.

Thermochromic pigments change colour when their temperature changes.

Photochromic pigments change their properties when exposed to **ultraviolet (UV) light**, e.g. glasses that turn into sunglasses.

Technical textiles have been developed e.g.

Conductive fabrics allow a small electrical current to safely pass through them. This technology is used for touch-screen gloves

5. Mechanical Devices

Most products rely on **movement** to work, eg in a pair of scissors the blades need to move together to cut. This movement is called a **motion**, and the motion of a product may be hidden or visible. The 4 types of **motion**:

Linear **Rotary** **Oscillating** **Reciprocating**



3. WOW WORDS

Fair Trade = Trade in which fair prices are paid to the farmers and workers who create products.

Finite Resources = Resource that can only be used once and is in limited supply. For example, oil is a finite resource.

Fossil Fuels = Natural, finite fuel formed from the remains of living organisms, eg oil, coal and natural gas.

Renewable energy = Power that is generated using natural resources that will not run out, eg wind and wave power.

Nomex = a technical textile which is flame-resistant material used for firefighters.

Kevlar = a technical textile tightly woven fabric that has great impact resistance.

6. Material Categories

Paper and Board: Papers are made from **wood pulp**. They are measured by **weight**, in grams per square metre (**gsm**).

Timber comes from **trees**, they can be categorised in two groups **softwoods** and **hardwoods**.

Metals are found naturally and are **mined** from the **earth** and can be categorised as **ferrous, non-ferrous** or **alloys**.

Polymers are formed by processing **crude oil** but they can be made from both **natural** and **synthetic** resources. They can be **thermoforming** or **thermosetting**.

Textiles can be either natural (from plants and animals) or synthetic (man made) fibres.



KNOW IT

How to describe a product:

What is it made from? Who is it for? When would it be used? Where is it used? How much does it cost? How has it been made?

Core technical Principles:

State what a smart material is.

State what a modern material is.

State what a technical textile is.

What biomimicry is.

The main source of energy used in the world is currently fossil fuels.

Know what fossil fuels are and where they come from.

The impact of new technologies on society.

A range of renewable energy sources: solar, wind, tidal, biomass.

Analysis is reflecting on your designs/ product and assessing its strengths and weaknesses.

Ergonomics is how comfortable/ easy a design is to use and how well it meets the users needs.

Maths and design and technology:

How to calculate percentages.

How to calculate area.

How to calculate volume.

How to read graphs and tables.

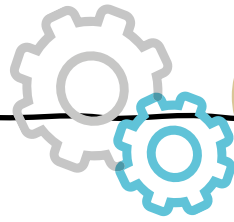

THINK IT

How to interpret products that are new:

What is my reaction to this product?

Who might the user or owner be?

Why might they want to buy it?

Is it designed well, if so, why/why not?

Is it easy to use?

How well is it made?

Is it well finished (polished, sanded, varnished)?

Is the cost appropriate?

What happens at the end of its product life? (recycled, landfill, can it be repaired/ reused)

Consider the environmental impact of designs:

When designing and manufacturing a product, it is important to consider its life cycle.

Life cycle is the time from a products manufacture, to its recycling or disposal, at the end of its useful life. We need to consider the 6 R's: Reduce, reuse, recycle, refuse, repair and rethink.

Core technical Principles:

Give an example of how a smart material can be used in a product.

Give an example of a modern material.

Give examples of technical textiles.

Give an example of how biomimicry has been used in development and innovation in engineering/ design.

Calculate the surface area of a product.

Calculate the volume of a product.

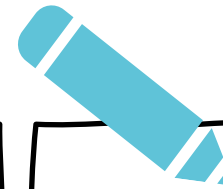

GRASP IT

Synthesis:

Would I want to own or use this product?

What influenced the appearance of a product and the way it works?

How might the design have been developed?

How would you test this to see..?

Could you redesign to improve a part of the design?

What innovation techniques could you use to improve it? Biomimicry? Divergent thinking?

Evaluation – according to criteria and state:

What is wrong with the product?

Why is this product more or less popular than other similar products?

What difficulties would manufactures have making this product?

Why have these materials been chosen?

Could you analyse the lifecycle of an existing product and advise opportunities where designers could make it more sustainable by using the 6 r's?

Could you explain how you could improve a product through the use of smart materials?

Could you find out how modern materials have improved the performance of products?

Year 11

D & T: Product Design

Core Technical Principals

Design & Technology: Timbers

1. Preparing Timber

The tree is '**felled**' (cut down). The tree trunks (logs) are stored in the forest before going to the sawmill. This allows some of the water content to evaporate. The logs are then transported to the sawmill. At the sawmill, the logs are cut into '**boards**' using equipment such as circular saws and bandsaws. This is called '**conversion**'. The first stage of conversion is a process called '**breaking down**', which means rough sawing. The second stage is called '**resawing**' and refers to more **accurate / precise** cutting and finishing, such as planing and further machining. The timber is then '**seasoned**' either by air drying or by kiln.

4. Manufactured Boards

Usually made from **waste wood** and **adhesive**. Used in **construction** for **interior furniture**. They are more **stable** than natural woods and are less likely to **warp** and **twist**. They are available in many **sheet sizes** and **thicknesses**.
Plywood - Layered in odd numbered sheets. Strong due to layers glued at 90° angles. Susceptible to splintering **Used** in sheds and cladding, furniture, flooring, boats.
MDF - will swell if exposed to moisture. Sheets can be heavy. Smooth finish. No grain.
Chipboard - Large chips of wood glued together under pressure, brittle, difficult to shape and finishes poorly, absorbent and low in cost.

2. Softwoods and Hardwoods

Timber comes from trees, which have to grow to full maturity before they can be cut down for wood. Timbers can be split into two categories: **softwoods** and **hardwoods**.

Softwood

Softwoods come from **coniferous** trees. These often have pines or needles, and they stay evergreen all year round - they do not lose leaves in the autumn. They are faster growing than hardwoods, making them cheaper to buy, and are considered a **sustainable** material. Examples of softwoods are: Paraná pine, Scots pine and Western red cedar.

Hardwood

Hardwoods come from **deciduous** trees, which have large flat leaves that fall in the autumn. Hardwoods take longer to grow, are not easily sourced and are expensive to buy. Examples of hardwoods are: Balsa, Beech, Jelutong, Mahogany and Oak.

5. Finishes

Some physical properties of timbers can be changed, such as colour and texture, by applying a surface **finish** to the wood. The way a timber looks can be altered through several methods: **staining, varnishing, oiling, waxing, painting**. This can also **increase** the **durability** of the product, **weather protect** and **prevent defects**.

3. WOW WORDS

Source = where a material comes from.

Hardwood = Timber from a deciduous tree. Slow growing and expensive.

Softwood = Timber from an evergreen or coniferous tree. Fast growing and cheap.

Deciduous = a tree that loses its leaves.

Seasoned = the process through which **excess water / moisture is removed**,

Tight-grained = Timber with a high ring count, slower growing and denser.

Loose-grained = Timber with a low ring count- faster growing.

Knot = where a branch would have been.

Weather resistant = A tight-grained timber has good water and heat resistance.

Stiff = A timber that does not bend easily.

Easy to work = easy to cut and shape.

6. Processes

Steaming: soaking thin lengths of wood or plywood in a steamer box makes the timber flexible enough to twist and bend.

Laminating: thin sheets of wood can be pressed together in a mould to form a three-dimensional structure.

CAD/CAM:

Laser cutters: cut and engrave thin sheet timber quickly and accurately including complex shapes.

CNC routers and milling machines:

uses a rotating cutting tool. This tool is able to move along multiple axes to create a range of shapes and designs.



KNOW IT

The categorisation and properties of hardwoods and softwoods.

Natural timber is harvested from deciduous (hardwoods) and coniferous (softwood) trees
Natural timber can be identified using a range of discriminators: weight, colour, grain, texture, durability and ease of working.

Natural timber is protected and aesthetically enhanced using different finishes.

Manufactured timbers are made from natural timbers and made from particles/fibres or laminates.

The stock forms of timber are: plank, board, strip, square, and dowel.

Timber defects include: shrinkage, splits, shakes, knots, fungal attack.

Hardwoods: beech, oak, mahogany, balsa and jelutong.

Softwoods: scots pine, western red cedar and parana pine.

Strengths, weaknesses of the following manufactured boards: plywood, MDF - medium density fibreboard, chipboard and hardboard. The impact on the environment of deforestation.

Designers should be changing society's view on waste and encouraging recycling.

How to undertake a life-cycle analysis of a material or product.

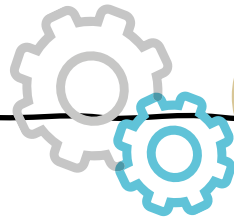

THINK IT

Explain the physical and working properties of hardwoods, softwoods and man-made boards: toughness, flexibility, grain structure, strength, absorbency, surface finish, colour and hardness.

Give examples of what manufactured timbers are used for: plywood, MDF (Medium Density Fibreboard), chipboard and veneered boards.

Give examples of material finishes for timber.

Give examples of what different softwoods and hardwoods are used for.

Explain the benefit of choosing timbers over non-renewable materials.

Explain the process of getting a timber from source to sale.

Explain which parts of products would use which stock forms for example dowel can be used in the axle of a toy car.

Explain how you could reduce the cost of a timber product by using veneers or material finishes on a cheaper timber.

Name the organisation who plant a tree for every tree they chop down.

Explain what sustainable forestry management is.

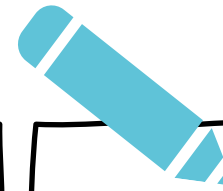

GRASP IT

Explain why materials are used for what products relating to their material properties e.g. oak is often used in wooden flooring because it is durable and has an attractive wood grain finish.

Consider if there are exceptions to the general rules e.g. Balsa wood is a hardwood but is not dense and is extremely lightweight and can be cut and shaped using a knife.

Explain how to apply finishes to natural and manufactured timber and how they can be used to improve the aesthetic appeal.

Evaluate the environmental impacts at each stage of producing a timber product.

Explain the impacts of felling trees on wildlife, habitat and the environment.

Consider the carbon footprint of transporting timber.

Explain the difference between air drying and kiln seasoning.

Explain the process of conversion.

Year 11

D & T: Product Design

Timbers